

STOP Shot

Turning ordinary moments into extraordinary pictures



Owner's Manual

Revision 1.9

Cognisys, Inc.

Where the left and right brain meet.

Copyright 2010 Cognisys, Inc.

Table of Contents

1. SAFETY INSTRUCTIONS.....	4
2. GETTING STARTED	4
2.1 PACKAGE CONTENTS	4
2.2 CONNECTIONS	5
3. OPERATION	7
3.1 OVERVIEW	7
3.2 GAIN CONTROL.....	8
3.3 GLOBAL CONFIGURATION	9
3.3.1 <i>Global Trigger Mode Overview</i>	9
3.3.2 <i>Loading/Saving configurations</i>	10
3.3.3 <i>Load Defaults</i>	12
3.3.4 <i>Backlighting</i>	12
3.3.5 <i>Sensor Power Off</i>	12
3.3.6 <i>Power Off Duration</i>	13
3.3.7 <i>Sequential Timeout</i>	14
3.4 OUTPUT CONFIGURATION.....	15
3.5 INDEPENDENT TRIGGERING	15
3.5.1 <i>Overview</i>	15
3.5.2 <i>Manual</i>	16
3.5.3 <i>Trigger</i>	17
3.5.4 <i>Cross-Beam sensor modes</i>	20
3.5.5 <i>Ballistics</i>	22
3.6 SEQUENTIAL TRIGGERING.....	25
3.6.1 <i>Overview</i>	25
3.6.2 <i>Manual Trigger</i>	27
3.6.3 <i>Input Trigger</i>	27
3.6.4 <i>Delayed Trigger</i>	27
3.7 TIME-LAPSE	30
3.8 SHUTTER LAG MEASUREMENT	32
4. ACCESSORIES	34
5. CONNECTIONS & CABLES	45
5.1 SENSOR/MIC INPUTS	45
5.2 TRIGGER OUTPUTS	45
5.3 ACTIVATING RELAYS.....	46
5.4 CROSS-BEAM SENSOR	47
6. TROUBLE TRIGGERING	49
7. SETUP EXAMPLES (GETTING THE ULTIMATE SHOT)	50

7.1	WATER DROPS	50
7.1.1	<i>Water-drop How-to</i>	52
7.2	WATER DROP KIT QUICK-START	56
7.3	BALLISTICS – TIPS AND TRICKS	57
7.4	WILDLIFE.....	58
7.4.1	<i>Lions, Tigers, and Bear</i>	58
7.4.2	<i>Of Mice and Men</i>	58
7.4.3	<i>The Catch-All</i>	59
8.	ANIMATED TIME-LAPSE MOVIES	62
9.	TROUBLESHOOTING.....	63
10.	SPECIFICATIONS.....	64
11.	WARRANTY	65
12.	GLOSSARY	66
13.	REVISION HISTORY.....	68

Table of Figures

Figure 1 - Typical Connection Diagram	5
Figure 2 - Sensor Power Disable	14
Figure 3 - Manual Mode Timing Diagram	17
Figure 4 - Trigger Timing Diagram.....	20
Figure 5 - Ballistics Timing.....	24
Figure 6 - Sequential Mode Timing Diagram	26
Figure 7 - Delay Synchronization.....	29
Figure 8 - Time Lapse Timing Diagram	31
Figure 9 - Microphone Connection	45
Figure 10 - Sensor Connection	45
Figure 11 - RCA connector	46
Figure 12 - Wiring an external relay.....	47
Figure 13 - Cross-beam connections.....	48
Figure 14 - Laser Diffuser	49
Figure 15 - A Sucker being Shot with a .22 Caliber Rifle	57

1. Safety Instructions

WARNING indicates a potentially hazardous situation which, if not avoided, could result in death or serious injury.

Follow all CAUTION notices to reduce the risk of personal injury, prevent damage to the StopShot module, accessories, and devices (cameras, flashes, etc). Failure to follow all CAUTION notices may void your warranty. CAUTION may also indicate a potentially hazardous situation which, if not avoided, may result in personal injury.

The safety alert symbol  precedes a general CAUTION or WARNING statement.

The electrical hazard symbol  precedes an electric shock hazard CAUTION or WARNING statement.

2. Getting Started

2.1 Package contents

The latest version of this manual is available at <http://www.cognisys-inc.com>.

The StopShot deluxe package contains the following:

1. StopShot Module (1)
2. AC/DC Power Adapter (1)
3. Operation Manual CD (1)
4. Beam Sensor – Infrared Transmitter and Receiver
5. Oak Base for Sensor components
6. 3 in - PC to Female RCA Cable
7. 6 ft - RCA M/M Cable
8. 6 ft - 3.5mm M/M Cable
9. 6 ft - 2.5mm M/M Cable

2.2 Connections

To connect the beam sensor use the 3.5mm cable and connect one end to the jack labeled “Sensor” on StopShot and the other end of the cable to the IR receiver as shown below in Figure 1. Then use the 2.5mm cable to connect the transmitter and receiver together. The 2.5mm cable provides power from the receiver to the transmitter.

Power to the StopShot module is provided through an AC to DC power adapter. Plug the power adapter into the StopShot module jack labeled “Power”, and plug the adapter into the wall. The unit will power up, display a splash screen, and then continue to the main screen.

Flashes and shutter control should be connected to the Trigger 1, Trigger 2, and/or Trigger 3 RCA jacks.



Figure 1 - Typical Connection Diagram

⚠ WARNING: High voltage flashes should NOT be connected to the StopShot module or any of its associated adapters/connectors/cables. Doing so could expose you to dangerously high voltages resulting in serious injury or death. All new flashes on the market do not expose high voltage on the hot-shoe. These are the flashes intended for use with the StopShot module. Please visit our web-site at <http://www.cognisys-inc.com> for a list of low-voltage flashes, or contact us via e-mail at: support@cognisys-inc.com.

 **WARNING:** Do not use StopShot to automate the firing of ballistics. Serious injury and/or death may occur.

 **CAUTION:** Only use the power adapter (cube) that came with the StopShot module. Use of other power adapters may damage the module.

 **CAUTION:** Do not use “Y” adapters for the trigger outputs to connect more than three devices. Some devices generate significant transients (like solenoids) that may damage sensitive equipment such as cameras and flashes. StopShot is protected from these transients but other electronics (such as flashes and cameras) may not be. It is acceptable to use a “Y” adapter to connect more than one device to a trigger output as long as the devices are similar. If you have any questions or concerns about device compatibility, please contact us at: support@cognisys-inc.com.

3. Operation

3.1 Overview

StopShot allows precise control over flashes, cameras, and other electronic devices. It may be configured to give virtually any combination or sequence of events. This allows for several different effects: Stopping water drops in time, projectiles paused at the moment they pierce an object, or even time-lapse imagery. Once comfortable with simple settings, advanced triggering can be used to coordinate complex series of events: Pushing a button to release a water drop from a solenoid controlled valve, crossing through a beam sensor, and then firing a high-speed flash.

The **SELECT** button moves the cursor from line to line on the display. The **UP** and **DOWN** button adjust the values for each line. The different modes of operation are listed in subsequent sections.

Settings will be saved across power cycles.

The main display of StopShot indicates how the three outputs are configured. The default settings are as follows:

```
== StopShot ==
> Trigger 1: Off
  Trigger 2: Off
  Trigger 3: Off
```

This indicates that all three outputs are configured to trigger on an input (see section 3.5.3 for details regarding the “*Trigger*” function). The “Off” indicates that this output is currently disabled. If you press the **UP** button, the value will increase to 50us. If you hold the **UP** button, the time will continue to increase. The longer you hold the **UP** button the faster the time will increase. This value is the time from when a trigger input is detected from a sensor to when the selected output will activate. Consider the following example:

```
== StopShot ==
> Trigger 1: 100.0 ms
  Trigger 2: 100.0 ms
  Trigger 3: 500.0 ms
```

If a sensor is activated (a beam is crossed, sound is detected, a vibration, etc), “Trigger 1” and “Trigger 2” outputs would activate simultaneously 100ms after the sensor detection. “Trigger 3”, however, would wait 500ms from sensor detection before activating the output. This main-screen “delay” is used for virtually all of StopShot’s operation modes.

3.2 Gain Control

The gain knob is used to adjust the sensitivity of StopShot to the trigger inputs. If using the microphone and the microphone gain is set to minimum, it would take a louder noise to cause StopShot to trigger (because the sensitivity is turned down). If the gain is set to maximum, then quiet noises will trigger. If ambient noise is triggering StopShot then turn the gain down.

When using the standard beam sensor the gain may be used to adjust the sensitivity. Decrease the gain if the sensor is triggering falsely due to ambient light or noise. For most applications that use the IR and laser beam sensors the gain should be set to the middle position. Digital inputs such as the cross-beam sensors should also have the gain set to the middle position.

To avoid false triggers is always best to keep the gain at the lowest setting while still reliably triggering. If the LED for a particular channel is on or flashing try turning the gain down to correct this issue. You may see this if you have a sensor cable attached to StopShot with no sensor plugged in and the gain turned all the way up.

3.3 Global Configuration

To enter StopShot's *Global Configuration*, press and hold the **CONFIG** button for two seconds. The display will change to indicate that you are now in the "Global Config" menu. To return to the main screen press the **CONFIG** button.

3.3.1 Global Trigger Mode Overview

There are four available global trigger modes ("*TMode*"). The "*Independent*" mode (default) means that if all the output channels are configured as triggers, once an input event occurs (an infra-red beam is crossed, or a sound threshold is exceeded) all three outputs will function simultaneously. For example, if each output trigger is configured for a 5ms delay, all three outputs will trigger at the same time. They are independent because they do not depend on the state of any other trigger. Other possible triggering options are discussed in section 3.5.

If the "*TMode*" in Global Configuration is set to "*Sequential*" and all three trigger outputs are set to 5ms, the first time an input event occurred the first output would fire, the next input event would cause the second output to fire, the third input event would cause the final third output to fire. Each trigger output may be configured to handle the input event differently and the options are discussed in section 3.6. If all the different types of configurations are scaring you – don't worry. We'll walk you through them step by step. In the section 7 of this manual, we'll show you exactly what settings are being used, how the shot was physically set up, and the picture we ended up with.

Another available "*TMode*" is "*Time Lapse*". This allows the Trigger 1 output to be fired at a specified interval. For help with this mode please see section 3.7 .

The final mode is *Shutter Lag Measurement* ("*Shutter Lag*"). This convenient feature allows the measurement of a camera's shutter lag. See section 3.8 for more information regarding this feature.

3.3.2 Loading/Saving configurations

StopShot automatically saves the last settings used, but sometimes it is more convenient to save different configurations for different setups (one configuration for insects, another for water-drops, and yet another for ballistics). To load or save the settings, press the **SELECT** button until the cursor is next to “Load/Save Config” and press the **UP** or **DOWN** button to enter the next screen.

```
== Global Config ==
  TMode: Independent
> Load/Save Config
  Load Defaults:      ->
```

From this screen you have two options – to either load or save the configuration. Press the **SELECT** button to change between the two options.

StopShot contains two pre-loaded configurations to simplify the initial set-up for water-drop photography. Preset 1 is called “Single drop”, and Preset 2 is “Drop on Drop”. You have the capability to over-write these presets with your own settings. See section 7.1.1 for more details regarding the specific setup for these presets.

Under the “Load” screen, you will see the following:

```
== Load Config ==
  1. Single drop
  Up/down to select.
```

Using the **UP** or **DOWN** buttons, you can scroll through the ten available configurations to retrieve. If they have never been saved with a configuration before it will show up as “empty” otherwise it will show the name you had previously saved. Once you have highlighted the desired configuration to load, press the **SELECT** button. This will take you to the main screen for this configuration. You can abort the loading screen by simply pressing the **CONFIG** button.

The process is similar for saving a configuration. Once “Save” is selected, you will see the following screen:

```
== Save Config ==
  1. Single drop
  Up/down to select.
```

Use the **UP** or **DOWN** buttons to select which configuration you would like to save. You can overwrite previously stored configurations. In this example, the **DOWN** button is pressed until an “empty” configuration is displayed.

```
== Save Config ==  
3. <empty>  
Up/down to select.
```

Once the desired configuration is selected, press the **SELECT** button. At this point you can enter a name. The cursor underlines your current position. The **UP** and **DOWN** buttons may be used to change the characters. Each time **SELECT** is pressed it will take you to the next character position. Keep pressing select until all the characters have been entered (A total of 12 may be used). Not all spaces need to be filled, just keep pressing select to finish the entry. Upon saving the configuration the screen will show:

```
== Save Config ==  
3. My own config  
Saved. Cfg exists.  
Up/down to select.
```

In this case the setting name was set to *"My own config"*. Press the **CONFIG** button to exit to the main screen.

3.3.3 Load Defaults

```
== Global Config ==  
  TMode: Independent  
  Load/Save Config  
> Load Defaults: ->
```

Once this option is selected, pressing the **UP** or **DOWN** button will reset all the current settings in StopShot to the factory default. If you've changed the configurations into something where it just isn't doing what you expected or it will take longer to get everything back to an initial condition – use this option. Beware that by selecting this option all the current settings will be lost. **Note:** This action will not erase your presets.

3.3.4 Backlighting

```
== Global Config ==  
> LCD Backlight: 10  
  Pwr Off: None  
  Pwr Toff: off ->
```

Backlighting (“*LCD Backlight*”) is on the second configuration page and is the amount of light that the display generates so that you can see the text on the screen. It may be beneficial to adjust the backlighting lower if working in low light situations. This preserves your eyes sensitivity to light and also doesn't cause unwanted secondary light in your exposure. To increase the backlighting, press the **UP** button. To decrease the backlighting, press the **DOWN** button. The backlighting may be adjusted from a range of 1 – 10.

3.3.5 Sensor Power Off

```
== Global Config ==  
  LCD Backlight: 10  
> Pwr Off: None  
  Pwr Toff: 250.0 ms ->
```

StopShot has the ability to disable sensor power once an input event occurs. This feature is extremely useful to disable laser transmitters prior to triggering a camera or flash. The available options for this Power Off (“*Pwr Off:*”) mode are:

1. “*None*”: The feature is disabled and the sensor(s) will remain powered.
2. “*Trig 1*”: Sensor power will be disabled when an input satisfies Trigger 1.
3. “*Trig 2*”: Same as #2 above, but with Trigger 2.
4. “*Trig 3*”: Same as #2 above, but with Trigger 3.
5. “*All*”: If any of the three trigger conditions are satisfied the sensor power will be disabled.

The sensor power is immediately disabled when an input condition is satisfied. If a trigger output is configured for a 50ms delay, the power will be disabled immediately when an input event occurs, wait 50ms, and then activate the trigger output. The different trigger output modes for StopShot are discussed in section 3.4. The “*Pwr Toff*” is the duration that the power will remain disabled.

Note: An important consideration when using this mode is that it may prevent other triggers from seeing an input for the duration that the sensor power is disabled.

3.3.6 Power Off Duration

```
== Global Config ==  
LCD Backlight: 10  
Pwr Off: None  
> Pwr Toff: off ->
```

This setting (“*Pwr Toff*”) allows the adjustment of the duration that the “Sensor Power Off” feature discussed in section 3.3.6 will leave the sensor(s) disabled. This duration is only used if the “*Pwr Off*” setting is set to a value other than “*None*”. Use the **UP** and **DOWN** buttons to adjust the duration. The sensor can be disabled longer than the delay that a trigger output is configured. Any sensor activity will be missed for the duration of this power off time since the sensor(s) are disabled.

See Figure 2 below to demonstrate the behavior of this feature.

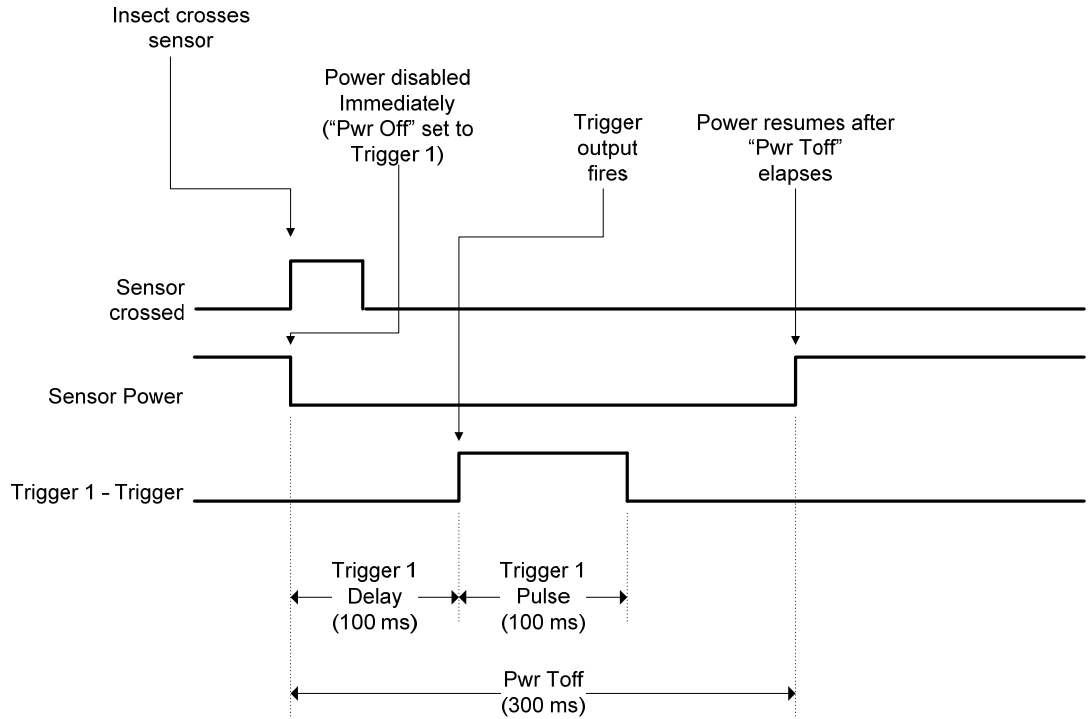

Figure 2 - Sensor Power Disable

This timing diagram shows Trigger 1 configured for a 100ms delay, “Pwr Off” set to “Trig 1”, and “Pwr Toff” set to 300ms. The sensor is immediately disabled when the input event (for example a laser beam being crossed) occurs. The re-enabling of the sensor power occurs independently from the Trigger 1 delay configuration. Don’t worry about all these settings yet – they’re discussed in detail starting with section 3.4.

3.3.7 Sequential Timeout

```

== Global Config ==
> SEQ Tout: off      ->

```

Sequential timeout (“SEQ Tout”) is only displayed if your trigger mode (See section 3.3.1) is set to “Sequential”. Once the trigger mode is set appropriately an arrow in the bottom right hand corner of the display appears indicating that additional settings are available.

Continue pressing the **SELECT** button past “Load Defaults:” to reach the second page. Sequential timeout is useful to abort a sequence if all of the triggering conditions are not met within the specified amount of time. When a sequence is aborted it will return to the first enabled trigger in the sequence. The **UP** or **DOWN** buttons adjust the value of this

timeout. To return to the previous configuration screen press the **SELECT** button again. To disable the sequential timeout (which will cause the sequence to wait forever) is achieved by holding the **DOWN** button until the timeout reaches zero. “*Off*” will be displayed when it is disabled. See section 3.6 for more details regarding Sequential operation.

NOTE: Sequential timeout may cause some “curious” behavior which may appear as StopShot not working properly. This is because the timeout will abort the sequence and restart it (which is its intended function). It takes precedence over any active trigger. Make sure you’re comfortable with your settings prior to enabling the timeout. As always, contact us with any questions.

3.4 Output Configuration

From the main screen, the **SELECT** button moves from one trigger output (“*Trigger*”) to the next. To change the output delay (if so configured) you may press and release the **UP** or **DOWN** button, or hold the button down to automatically increment /decrement the value. In this way one or more trigger outputs may be activated.

To change the configuration of each output, first press the **SELECT** button until the cursor is next to the “*trigger*” output you want to change. Press the **CONFIG** button. This will bring up the output configuration screen. This screen enables each trigger output to be configured in a different way by changing the parameters described in the sections below. The trigger output type (“*T Mode*”) is adjusted by using the **UP** and **DOWN** buttons. The **SELECT** button moves from one configuration parameter to the next. If an arrow appears on the right side of the screen that indicates that an additional screen of configurations is available. As you press **SELECT** it will switch to the next screen automatically. To return back to the main screen, press the **CONFIG** button again. The main screen is changed to indicate how each output is configured.

3.5 Independent Triggering

3.5.1 Overview

Independent triggering means that the output timers/triggers operate completely independent of each other. Independent triggering is a “Global Configuration”. Once this global configuration is set (described in the “Global Configuration” section 3.3 above), the output modes below are available.

3.5.2 Manual

“Manual” trigger mode requires an **UP/DOWN** button press to activate. To change an output to “Manual” configuration, from the main screen press the **SELECT** button until the desired trigger output is selected. Press the **CONFIG** button. This will bring up the timer configuration screen. Press the **UP/DOWN** buttons until the “*T Mode*” is changed to “Manual”.

```
> T1 Mode: Manual
  # Pul se: 1
  Tpul se1: 500.0 ms
  Toff1: 100.0 ms
```

With this type of output you have the option of adjusting the duration of the output pulse that is generated. It functions exactly as discussed in the “*Trigger*” mode (section 3.5.3). The number of pulses (“*# Pulse*”) may be set to a value greater than one if multiple trigger output pulses are required. This could be used to generate multiple initial events (such as multiple water drops). “*Tpulse1*” is the duration that the output is active and “*Toff*” is used as the off-time between pulses provided the number of pulses is greater than one. This allows complete flexibility for the on and off duration of the output. If you wish to adjust the on and off times of the pulses independently, StopShot allows up to three unique on/off durations. If “*# Pulse*” is set to greater than three, all subsequent pulses will use the time of “*Tpulse3*” and “*Toff3*”.

Press the **CONFIG** button to return back to the main screen. The “Manual” mode is activated by pressing the **UP/DOWN** button when the cursor is next to this trigger output. If the cursor is not next to the desired trigger output, press the **SELECT** button until the cursor is next to it.

Manual triggering can also be used in sequential mode for staging shots. This allows a sequence of events to start upon a button press. The maximum number of pulses that can be generated is 1000.

Once a manual event is triggered, it may be aborted by pressing either the **UP** or **DOWN** button.

Figure 3 illustrates the configuration below:

```
> T1 Mode: Manual
  # Pul se: 3
  Pul se1: 500.0 ms
  Toff1: 500.0 ms
```

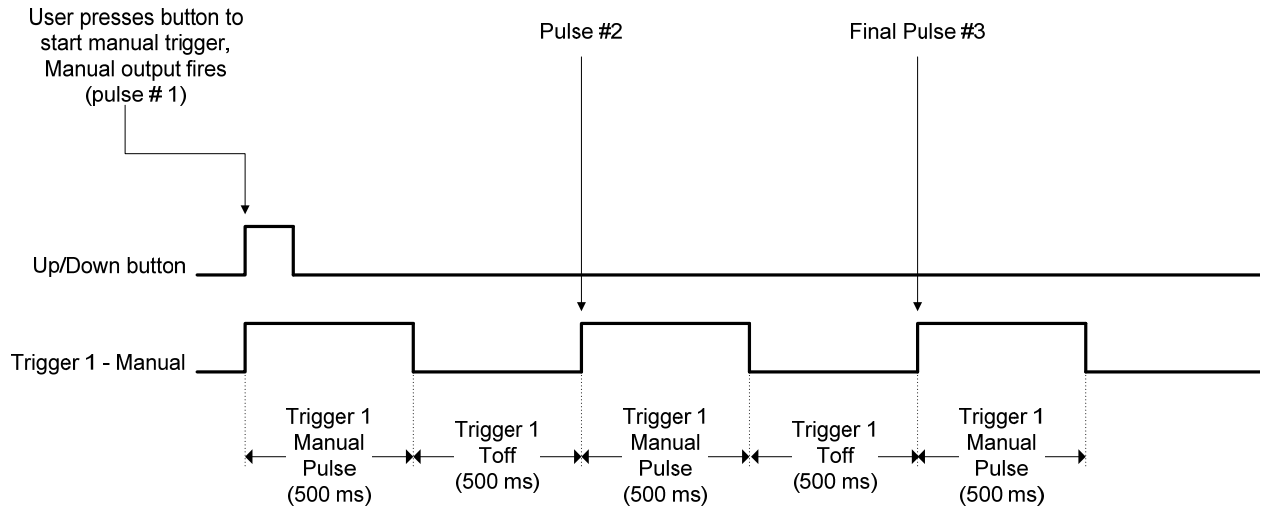

Figure 3 - Manual Mode Timing Diagram

Since “Manual” mode is frequently used for water drops, a valve “purge” feature may be enabled by holding down the **UP** or **DOWN** button for at least one second. This will activate the trigger output allowing the water valve to purge any trapped air or fluid for as long as one of the buttons remains pressed. The display will show “Purging” while this feature is activated.

3.5.3 Trigger

All three trigger outputs may be configured to react to a sensor input. When a trigger output’s mode (“T Mode”) is configured as “Trigger”, an input event is required. This is the mode that is required for using a beam sensor or microphone input. To change an output to “Trigger”, from the main screen press the **SELECT** button until the desired output is selected. Press the **CONFIG** button. This will bring up the Timer Configuration screen. Press the **UP/DOWN** buttons until the “T Mode” is changed to “Trigger”.

```

> T1 Mode:  Trigger
  # Pulse:   1
  TPulse1:  500.0 ms
  Toff1:    100.0 ms  ->

```

In this trigger mode you have additional options to modify (if required).

Pulse:

"# Pulse" specifies the number of pulses this output should generate once triggered. See the section 3.5.2 "Manual" Triggering for additional information regarding "# Pulse" .

Pulse1:

With this type of output you have the option of adjusting the first output pulse that is generated. This is the "Pulse1" field. The default is 500ms, but may be adjusted as necessary for your application. Some loads may have a minimum pulse time before they will trigger. For electro-mechanical devices such as a relay controlling a solenoid, you may need to increase this time. Cameras and flashes are generally edge sensitive and the pulse duration can be left at the default. This duration may be adjusted to "Latch" for sequential mode, discussed in section 3.6. Note: Some devices such as flashes are "edge-sensitive", that is, they fire when the output transitions. Increasing the duration of "Pulse1" has no effect on these type of devices because they only trigger on the transition. Devices like relays, water valves, and solenoids are "level-sensitive" in that they will remain active for the duration of the pulse.

Toff1:

"Toff1" is the duration the output remains off following the first "Pulse1".

See the section 3.5.2 "Manual" Triggering for additional information regarding "Toff" .

Pulse2:

Pressing the **SELECT** button through the bottom of the first configuration page will reveal a second list of configurations:

```
> Pul se2: Same
  Toff2: Same
  Pul se3+: Same
  Toff3+: Same ->
```

When the number of desired pulses on an output (See "# Pulse" above) is set to greater than one, you have the option of choosing the second pulse to be a different duration than the first. StopShot defaults to "Same", meaning that the second pulse after the first will be the same as the "TPulse" duration. You can use the **UP** or **DOWN** button to adjust the timing of "Pulse2". If you want to return back to "Same", hold the **DOWN** button continuously until the time counts down. Eventually "Same" will be displayed and the time of "TPulse2" will again track the duration of "TPulse".

Toff2:

"Toff2" is the duration the second output pulse remains off following "Pulse2".

Pulse3+:

If “# Pulse” is three or greater the value of “Pulse3+” will control the on time of the trigger output. It functions similarly to “Pulse2” but controls the third and all future pulses. “# Pulse” must be set to a value of three or greater for this to have any effect.

Toff3+:

Similarly to “Toff2”, this controls the off time for the third and future pulses. “# Pulse” must be set to a value of three or greater for this to have any effect.

Incrm:

Pressing the **SELECT** button will reveal the third and final trigger configuration. This timer mode has the option to automatically increment the timer’s main delay every time an event occurs by adjusting the “Incrm” configuration. If an event is easily repeatable and this increment is set you can create a simulated “time lapse” for some quickly occurring event (like a drop of water falling).

```
>   I ncrm:  Off
      B l ank:  Off
                                     ->
```

If this value is set to 10.0 ms, and from the main screen the trigger output is set to 100.0 ms, every time a trigger occurs the delay would increase by 10ms. The delay setting will be updated on the main screen following each trigger event. The first time the trigger would wait 100 ms. The second: 110 ms. The third: 120 ms. Every time StopShot activates the trigger output the delay on the main screen will be incremented by the “Incrm” value. If you want to start the sequence over simply adjust the trigger output value on the main screen back to its original value using the **UP/DOWN** buttons.

Blank:

Additionally, you can adjust “Blank”, which is the amount of time that the input is ignored after the output pulse is complete. Let’s say the following settings are used:

```
>   T1 Mode:  Tri gger
      # Pul se:  1
      Pul se1:  500. 0 ms
      Toff1:   100. 0 ms
                                     ->
```

```
>   I ncrm:  Off
      B l ank:  200. 0 ms
                                     ->
```

In this example, “Pulse” is set to 500ms, and “Blank” is set to 200ms. When an input event occurs (for example, a beam sensor being crossed), the trigger output will delay by whatever

value is entered on the main screen, generate a 500ms pulse, and then wait 200ms before looking for an input again. “Blank” is useful for ignoring all but the first of a series of rapidly occurring events. If the trigger output is being used to control a flash this allows time for it to fully charge before triggering again.

Figure 4 demonstrates the timing functionality of the “Trigger” mode. The timing events are initiated on the rising edge of the sensor input (“Trigger In” below).

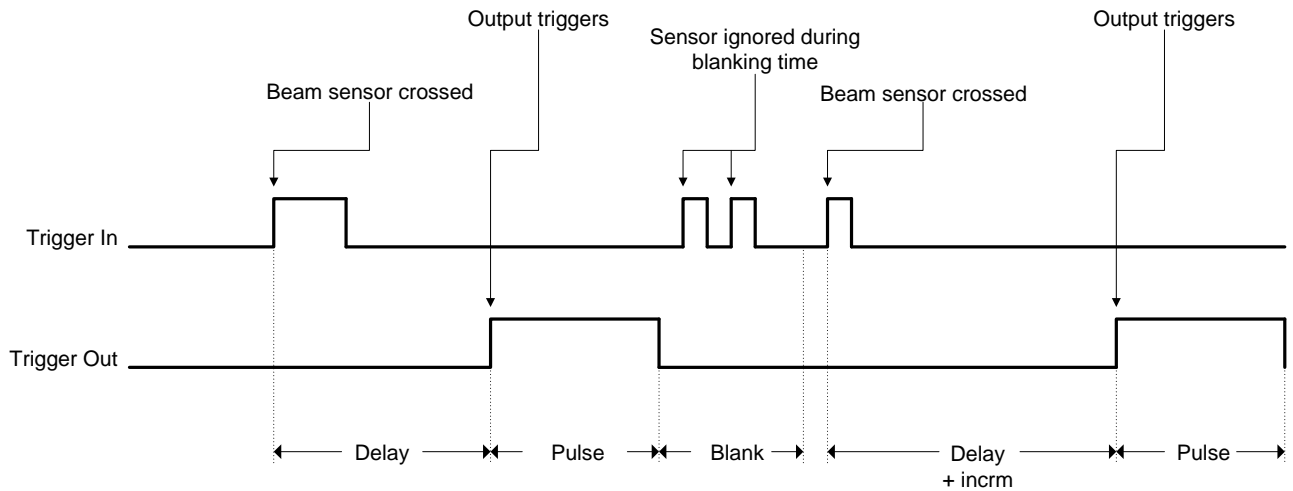

Figure 4 - Trigger Timing Diagram

3.5.4 Cross-Beam sensor modes

If you have purchased the cross-beam sensor additional trigger modes are available. These modes are present in all StopShot modules so if you decide to purchase the beam sensor at a later date no software upgrade is required. The cross beam sensor opens up a multitude of options for creative triggering especially for capturing things in the natural world like insects and birds.

To change a trigger output to one of the cross-beam sensor configurations, from the main screen press the **SELECT** button until the desired trigger output is selected. Press the **CONFIG** button. This will bring up the Timer Configuration screen. Press the **UP/DOWN** buttons until the “T Mode” is changed to the desired cross-beam mode. These are discussed below.

See section “5.4 - Cross-beam Sensor” for instructions on connecting this sensor.

3.5.4.1 X-Beam A

In this trigger mode configuration only crossing beam “A” of the cross-beam sensor is considered a trigger condition. Crossing beam “B” or both simultaneously will have no

effect. For this mode to work properly, beam “B” must be active (transmitter “B” aligned with receiver “B”). An example of this mode would be using it in conjunction with the “X-Beam B” mode to open the camera shutter when beam “A” is crossed and then firing the flash when beam “B” is crossed.

3.5.4.2 X-Beam B

This mode functions identically to “X-Beam A” above, but uses beam “B”.

3.5.4.3 X-Beam a&b

This is a true cross-beam configuration. Both beams “A” and “B” must be broken simultaneously for a trigger condition to be considered valid. The main screen will display “XBS a&b” for this mode. Breaking only beam “A” or “B” will not be considered a input trigger. This mode is useful for detecting objects in a tightly controlled area (especially if lasers are used).

The following configurations are available for this sensor:

```
> T1 Mode: X-Beam a&b
# Pul se: 1
Pul se1: 500.0 ms
Toff1: 100.0 ms ->
```

These configurations function identically to the “Trigger” mode in section 3.5.3.

3.5.4.4 X-Beam a|b

In this configuration “A” or “B” will create a trigger condition for StopShot. The main screen will display “XBS a|b”. Use this sensor mode when it doesn’t matter which sensor is activated. The possible configurations for this mode are identical to the “X-Beam a&b” mode.

3.5.4.5 X-Beam a->b

The main screen will display “XBS a->b” for this mode. Use this mode if you want to trigger on an object only moving in one direction. A good example would be capturing a bird entering a nest but not leaving. The configuration for this mode is shown below:

```
> T1 Mode: X-Beam a->b
# Pul se: 1
Pul se1: 500.0 ms
Toff1: 100.0 ms ->
```

The final page of the cross-beam configuration reveals the following:

```
> Timeout: 250.0 ms
   Blank: Off
                                     ->
```

“Pulse” and “Toff” function the same as the previous modes (see section 3.5.3). When beam “A” is broken, the letter “a” in “XBS a->b” on the main screen will be capitalized (“XBS A->b”) to indicate that the “A” condition has been met and StopShot is waiting for the “B” condition. If the “B” beam is not broken prior to the configured “timeout” then the letter “A” will revert back to lower-case indicating that StopShot is once again waiting for the “A” condition. This “timeout” option is a way for the trigger to re-arm if event “B” never occurs. In the example of the bird entering a nest – If the bird flew close to the nest but did not land, it would allow StopShot to re-arm the trigger output for the next time the bird would approach the nest.

“Blank” functions identically to the “Trigger” mode (see section 3.5.3).

3.5.4.6 X-Beam b->a

This mode functions the same as “X-Beam a->b” but beam “B” must be broken first, followed by “A”. This allows direction reversal through the sensors without having to physically move them.

3.5.5 Ballistics

Ballistics mode (“Ballist” on the main screen) simplifies triggering on objects that pass between two beam sensors. For this mode you may use the cross-beam kit or two infra-red beams connected using a 3.5mm “Y” connector. This configuration virtually eliminates the variability involved with capturing something that has an unpredictable (or unknown) speed. In this mode, StopShot measures the time elapsed between the two beam sensors and then triggers the output that duration (plus a configurable delay). By pressing the **CONFIG** button, you have the following configurations that you may adjust for this mode:

```
> T1 Mode: Ballistics
   # Pulse: 1
   Pulse1: 500.0 ms
   Toff1: 100.0 ms
                                     ->
```

```
> Pulse2: Same
   Toff2: Same
   Pulse3+: Same
   Toff3+: Same
                                     ->
```

```
> Timeout: 250.0 ms
   Dist Mult: 1
                                     ->
```

Similar to the other modes, the *"Pulse1"* time is the duration that the output will be active. *"Timeout"* is the maximum time that an object can take to travel from the first sensor to the second before StopShot resets its ballistics capture. This timeout feature is useful to abort the capture event and reset in the event that an object never crosses the second sensor. *"Dist Mult"* is the distance multiplier used. Here is an example of a ballistics sensor setup using the above configuration. The first and second sensors are spaced exactly six inches apart from each other. If an object crosses the first sensor and the second sensor within 250ms, the output will fire when the object is six inches past the second sensor. If the *"Dist Mult"* was to *"2"*, the output will fire 12 inches after the second sensor.

Some notes regarding Ballistics mode:

1. Only one Trigger may be configured for ballistics mode at a time. This is due to the precise control and resources required to create repeatable timing.
2. The time to cross between beam sensors may range from 100us to hours.
3. The object must be traveling fast enough to prevent the sensor from reaching a "steady state" dark condition. Otherwise StopShot will measure the time between light->dark then dark->light.
4. Despite the name "Ballistics" this mode may also be used to capture wildlife.
5. Laser sensors are more difficult to align with the projectile. The beam-width of the laser also requires precise alignment. We recommend using infrared transmitters for capturing small projectiles; they are much more forgiving to align.

Shown below is the timing, measurement, and output triggering of Ballistics mode.

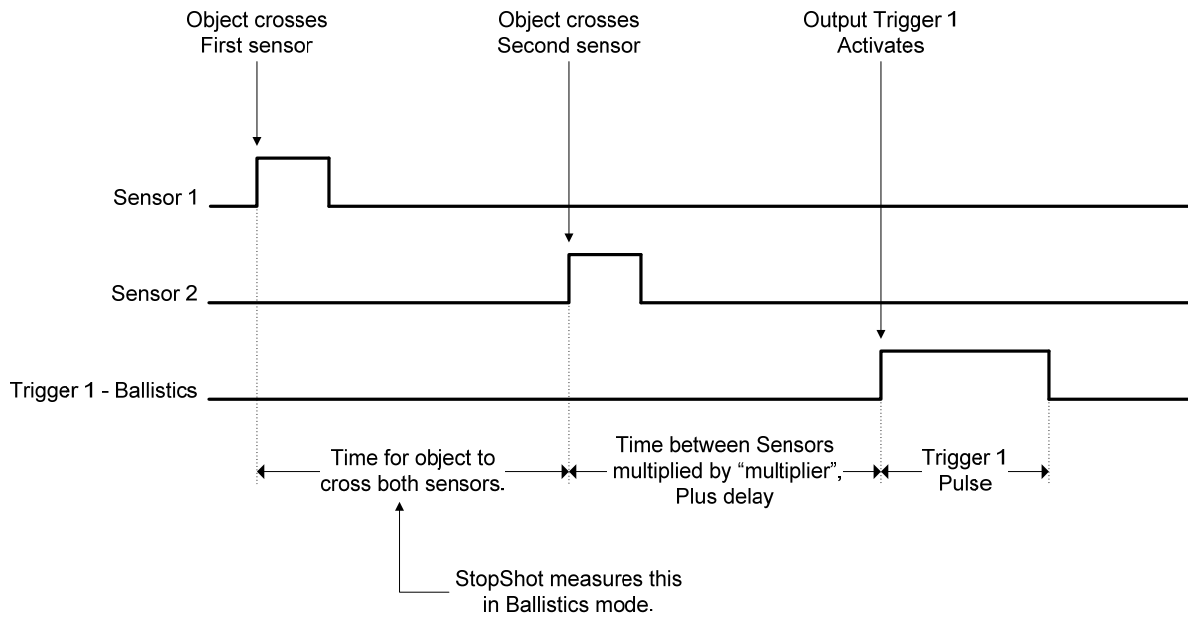

Figure 5 - Ballistics Timing

3.6 Sequential Triggering

3.6.1 Overview

Sequential triggering indicates that the output timers/triggers depend on each other.

Sequential triggering is a Global Configuration. Once this Global Configuration is set (described in section 3.3.1), the output modes below are available. When in Sequential Triggering, “SEQ” is displayed in the upper-right hand corner of the main screen to differentiate between this mode and Independent mode.

Sequential mode expands the number of creative shot possibilities. Let’s say the following configuration is used:

```
== StopShot ==          SEQ
> Manual 1:  Wai ti ng
  Trigger 2: 200.0 ms
  Del ay 3:  10.0 ms
```

In this example, trigger output 1 is set up as “Manual”, output 2 set as “Trigger”, and output 3 set as “Delay”. With this configuration, trigger output 1 will run to a solenoid controlled water valve, output 2 to a shutter on a camera, and output 3 to a flash. When the manual output is activated by pressing the **UP/DOWN** button, the water drop would be released from the water valve. StopShot would then advance to the output 2 configuration and wait for the water drop to cross the beam detector. Once it crosses the beam detector, output 2 will wait the configured amount of time (200.0 ms) to open the shutter on the camera. Output 3 will delay long enough for the shutter lag to expire, and then fire the flash. This is a fairly complicated setup, but it would allow you to take a high speed picture with the lights on in a room. See Figure 6 below for a timing diagram of this scenario.

As each sequential step is completed, the “:” next to the step will change to a “*” to indicate that it is complete.

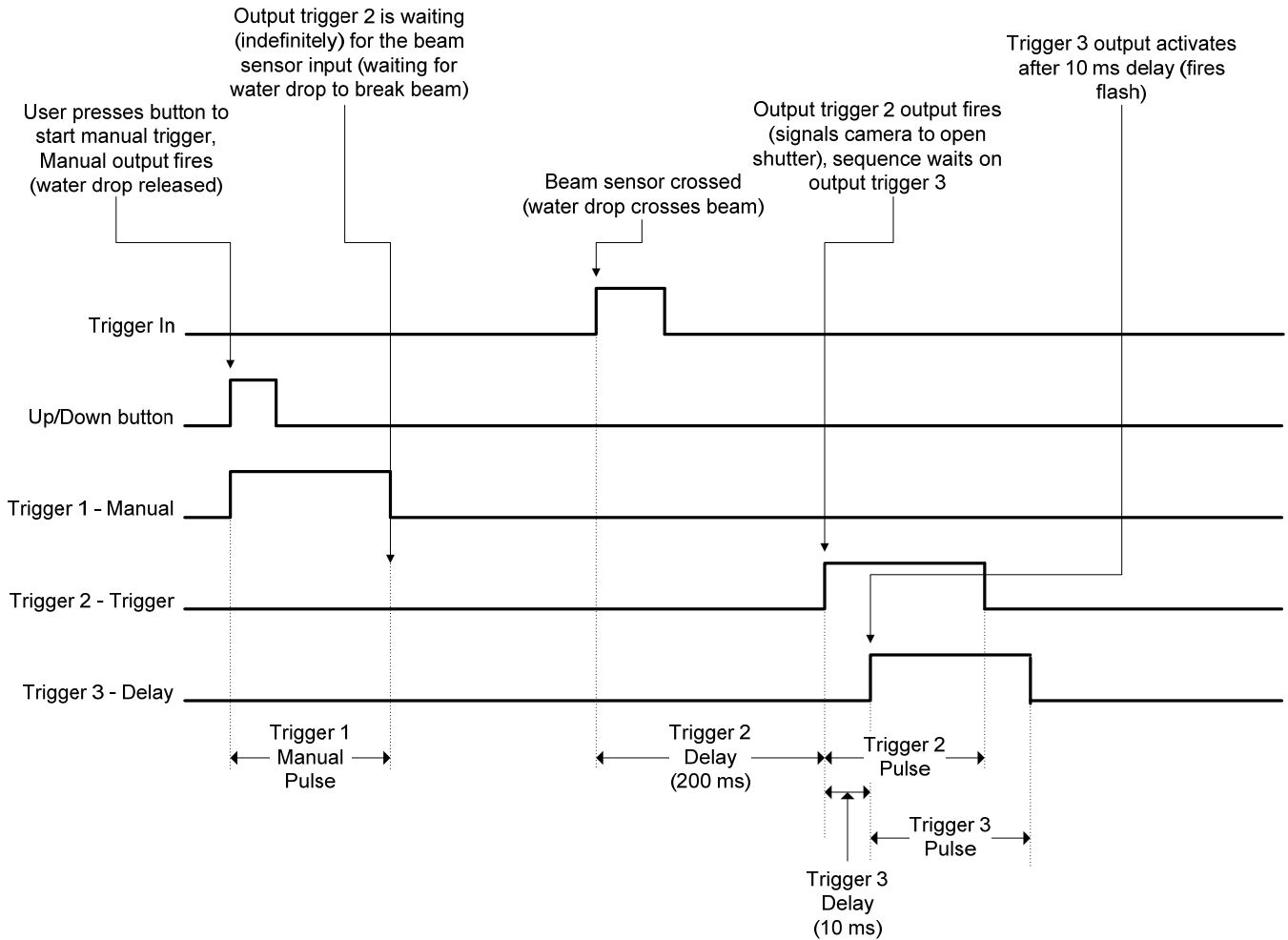

Figure 6 - Sequential Mode Timing Diagram

If a trigger output is configured as a “Trigger” but the delay on the main screen is set to “off”, then the subsequent trigger outputs will be used. The sequence will be aborted if a configuration for a trigger output is entered (by pressing the **CONFIG** button).

There is an optional sequential mode timeout that may be adjusted as necessary. See section 3.3.7 for details on how to enable the sequential timeout. In the above usage scenario if the timeout was set to one second, StopShot would wait for trigger output 2 up to one second before resetting the sequence and waiting for trigger 1 (configured for manual mode). This is the maximum timeout to wait for each step of the sequence not the time to wait for the entire sequence. Care should be taken when setting this timeout. Time timeout can be set short enough to abort the current trigger output (i.e., setting a two second output pulse would be aborted after one second in the above example). As stated above, the “:” next to each step is

updated with a “*” as it completes. If this timeout occurs all the steps will revert to showing the “:” to indicate that StopShot is once again waiting for the first step.

Sequential mode has an additional feature that lets the “Pulse” duration of the trigger outputs to be configured as “Latched”. This means that the output will stay active until either the sequence completes or it times out. When adjusting the duration of “Pulse”, use the **DOWN** button to adjust it to the minimum. Once the minimum is reached, “Latched” will be displayed.

NOTE: Do not set the final trigger in the sequence to “Latched”. Since it is the final output, it will be disabled immediately (i.e., will not trigger the output).

NOTE: Setting the pulse duration to “Latched” when multiple pulses are selected will not generate multiple pulses on that trigger output. The output will stay active for the duration of the sequence (The latched feature overrides).

At the end of any sequence there is a forced one millisecond delay.

3.6.2 Manual Trigger

Manual triggering is discussed in the Independent Triggering section 3.5.2. “Manual” mode is generally only used on trigger output 1 functioning as the initiating condition (a button press) for a sequence of outputs. It can, however, be used on outputs 2 and 3. Because “Manual” mode is initiated by pressing the **UP** or **DOWN** buttons, you will have to press the **SELECT** button so the indicator is next to the proper “Manual” trigger, and then press the **UP** or **DOWN** button.

3.6.3 Input Trigger

The “Trigger” mode for Sequential Triggering functions exactly like the Independent Triggering mode. See the Independent Triggering section 3.5.3 for more details.

3.6.4 Delayed Trigger

The “Delay” triggering configuration is only available in Sequential Triggering mode. It is a simple way to add a delay in activating the trigger output between steps. The “Delay” mode is typically used for Trigger 2 or Trigger 3. It may be used on Trigger 1, but in this mode the sequence will start immediately (the delay will initiate the moment it is configured and begin).

To change an output mode to “Delay”, from the main screen press the **SELECT** button until the desired trigger output is selected. Press the **CONFIG** button. This will bring up the configuration screen for the specific trigger output. Press the **UP/DOWN** buttons until the “T Mode” is changed to “Delay”.

```
> T2 Mode: Delay
# Pulse: 1
Pulse1: 500.0 ms
Toff: 100.0 ms ->
```

```
> Pulse2: Same
Toff2: Same
Pulse3+: Same
Toff3+: Same ->
```

```
> Incrm: Off
Sync: No
->
```

Just like the independent “Trigger” mode you have the option of adjusting “Pulse” and “Incrm” as needed. An additional configuration is “Sync”. When “Sync” is set to “No”, the delay time will start from the falling edge of the previous trigger output (it starts after the trigger output LED is off – so after the “Pulse” time has expired). If “Sync” is set to “Yes”, it will start from the rising edge of the previous trigger output (the moment the output LED turns on).

“Figure 7 - Delay Synchronization” below is using the following configuration:

```
== StopShot == SEQ
> Trigger 1: 100.0 ms
Delay 2: 250.0 ms
Trigger 3: Off
```

Note the behavior difference of “Delay 2” when “Trigger 1” changes its output.

Delay – Sync = No

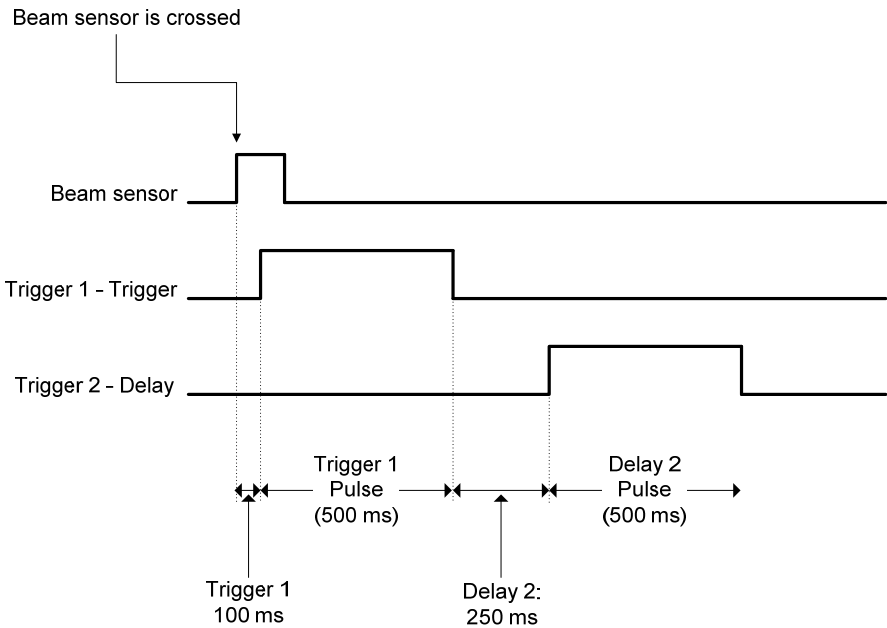

Delay – Sync = Yes

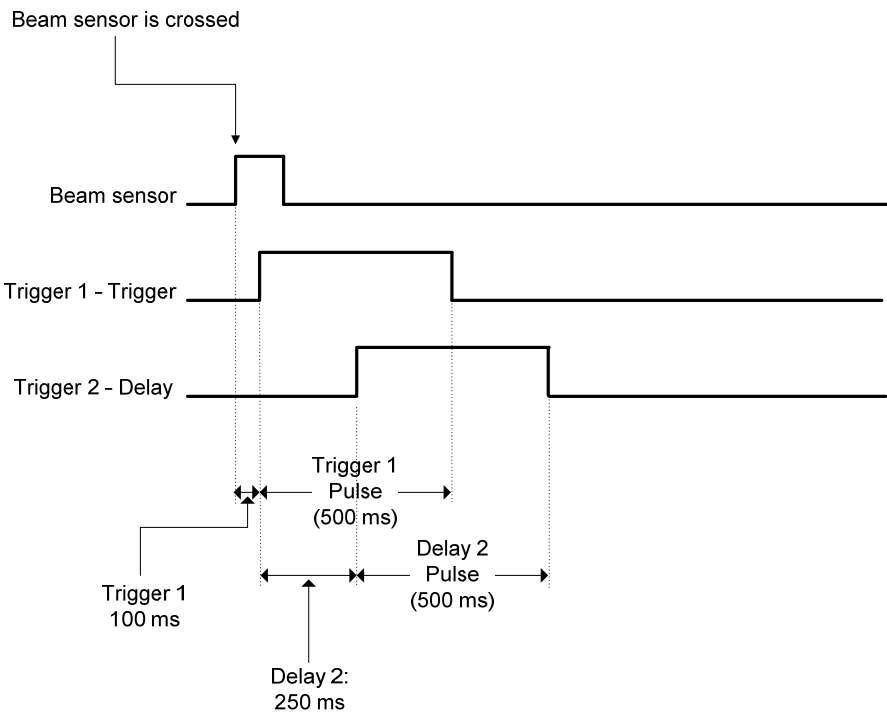

Figure 7 - Delay Synchronization

3.7 Time-Lapse

Time Lapse is another available “Global Configuration”. Once this global configuration is selected (described in the “Global Configuration” section 3.3.1) Time Lapse mode will be enabled. This is useful for creating a series of shots for something that changes slowly: A sunrise, clouds traversing the sky, plants growing, or even congress voting.

The time-lapse interval is adjusted via the main screen using the **UP/DOWN** buttons. See the example settings below:

```
== StopShot ==  
> TLapse 1: 2.0 sec  
   Remai ni ng: 1.9 sec  
   Count: 3
```

You also have the option to adjust the “Pulse” configuration. Like other modes, press the **CONFIG** button. It will bring up the following configuration screen:

```
TLapse Config:  
> Pul se: 500.0 ms
```

In this example, the “Pulse” configuration is left at the default of 500.0 ms, and the interval delay is set to two seconds (on the main screen). Since the two seconds is the time between the pulses, there would be 2.0 seconds (interval time on the main screen) plus the 0.500 seconds (“Pulse”), for a total of 2.50 seconds between pictures.

As shown in the above display, Time Lapse mode will show the remaining time before the next trigger event (“Remaining”) and also the number of times (“Count”) that the trigger output has fired. “Count” will limit itself at 9,999 trigger events. See Figure 8 for a timing diagram. Only trigger output 1 is used for Time Lapse mode.

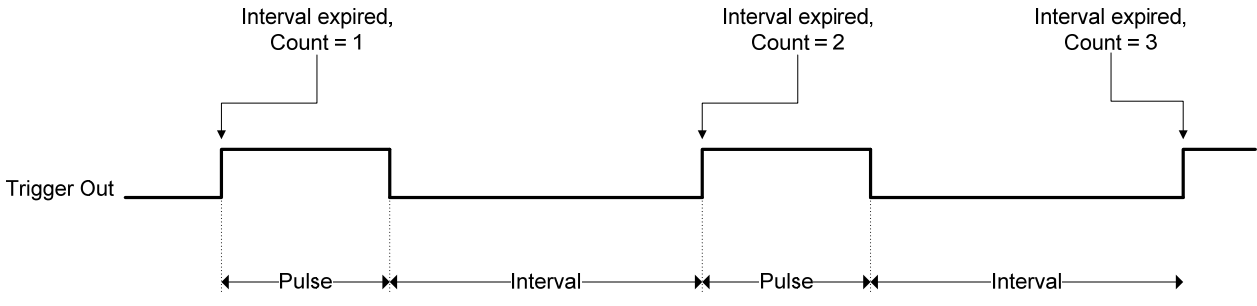

Figure 8 - Time Lapse Timing Diagram

3.8 Shutter Lag Measurement

Shutter lag can be the nemesis of high-speed photographers. Knowing the shutter lag of your camera is critical when trying to synchronize the exposure with external flashes. StopShot provides excellent control over timing events, whether it is a camera or a flash. Unfortunately, cameras introduce a significant amount of delay when capturing an event. Shutter lag does vary from one camera manufacturer to another. To make matters worse, the delay is likely variable based on the amount of processing that the camera performs and the settings of the camera. There are some tricks to get most cameras to behave so that the shutter lag is consistent but even with those tricks the only way to determine the lag is through a series of photographs and a handful of patience. That is where the *Shutter Lag Measurement* (“Tmode” set to “Shutter Lag”) is very useful.

To perform the shutter lag measurement, you must have a StopShot shutter cable for your camera. Attach the shutter cable to “Trigger 1”, and the other end to your camera. The camera will need a flash attached or be a model that has an integrated flash. If using an integrated flash, be sure the flash is already up. Attach the infrared sensor to StopShot’s “sensor” input. The infrared transmitter does not need to be connected.

To configure StopShot to measure the shutter lag of a camera, press and hold the **CONFIG** button for two seconds until the global configuration screen appears. Press **SELECT** until “TMode” is selected. Use the **UP/DOWN** buttons until “TMode” changes to “Shutter Lag”.

```
== Global Config ==  
> TMode: Shutter Lag  
Load/Save Config  
Load Defaults: ->
```

Press the **CONFIG** button to return to the main screen. You will see the following on the display indicating StopShot is waiting for a button press to start the measurement:

```
Up/down to start  
Lag Measurement  
Duration: 0.0 ms
```

If the gain knob is set too high, it is possible for ambient light to falsely trigger the shutter lag measurement. Adjust the gain to the middle position as this will prevent StopShot from triggering on changes in ambient light.

When you press the **UP** or **DOWN** button to start the measurement, StopShot will activate “Trigger 1” and then measure the amount of time it takes for the camera to fire the flash. This provides an accurate measurement of how long from when a camera is told to take a picture to when it gets around to it.

Up/down to start Lag Measurement Duration: 65.2 ms
--

StopShot will wait up to one second for the camera and flash to fire. If it does not receive a flash input within that one second, you will see the following:

Up/down to start Lag Measurement Duration: Time out.
--

If the flash fired within that one second period, double-check the camera shutter cable. If that appears to be good then re-adjust the sensor and try again.

There are many variables that come into play with shutter lag. Auto-focus, metering, and even the LCD preview being active can affect the duration. For some cameras (such as Canon) the lag can be significantly reduced by enabling "Mirror Lock-up" in the custom functions settings. In fact this is the only way with a Canon camera to make the shutter lag consistent from shot to shot.

4. Accessories

IR Beam Sensor [IR_S03]



Features:

- Invisible beam will not show in pictures
- Great for water-drops and ballistics
- May be used to measure flash duration
- Excellent sensitivity
- Adjustable power
- Focusing lens available
- 6 ft (1.8 m) IR range (with optional lens)
- 6 ft 3.5mm and 6 ft 2.5mm cable included

This IR (infrared) Curtain for StopShot contains both an IR transmitter and receiver. It can be used to capture anything that moves between the elements. It works great for water drops and ballistics. It is sensitive enough to be triggered by a .22 caliber bullet. The sensor's oak base is designed to be mounted on a standard 1/2" pipe clamp. Shown to the right is a focusing lens (not included) to improve the range of the infrared beam. This lens should not be used when the sensors are close together as it will saturate the receiver and negatively impact the sensitivity. The transmitter for this sensor has a power control knob to adjust the power output. The lowest setting (counter-clockwise) should be used when the sensor is placed on the provided oak stand. This setting will maximize sensitivity at this short distance. If the sensor is used with more distance between the elements the knob may be moved clockwise to a higher power setting to increase the range. The lowest power-level possible that successfully triggers should be used to improve sensor sensitivity.



This is the sensor that is included with the deluxe package.

Infrared Beam Sensor - Transmitter/Receiver Specifications				
	Min	Typical	Max	Units
Input Voltage (Transmitter)	4.0	4.5	5.0	V
IR Transmitter Current		47		mA
Range (no lens)		1.0		Ft
Range (with lens)	6ft			Ft

Cross-Beam Infrared Transmitter/Receiver [XBS_IR02]



- Two transmitters and two receivers
- 6+ feet (182 cm) IR range
- Dual-axis triggering
- Conditional triggering (A followed by B, but within a certain time)
- Optional tripod mount available for sensors
- LED indicator for incident light on receivers
- Two 6 ft 3.5mm and two 6 ft 2.5 mm cables included.

Cross beam sensors add a whole new dimension to your triggering capability (literally). They work excellent for subjects whose trajectories are not as defined as water drops or projectiles. This cross beam sensor was designed for capturing images of insects, birds, and other less predictable creatures. See section 3.5.4 for all of the different triggering modes for these sensors.

Receiver A includes a tri-colored LED (mounted on the back) to indicate when each receiver is lined up correctly. See section 5.4 for details. The infrared version of this sensor has the advantage of having an invisible beam (unlike the red laser light). The disadvantage of IR is the beam size is larger, making it difficult to capture extremely small objects like insects. A lens (included as shown above) on the IR transmitters will yield a range in excess of six feet. For short distances the lens should be removed. The lens focuses the IR beam and if it remains attached at short distances it will saturate the receiver with IR light reducing its sensitivity. This may cause the receiver to not detect small objects crossing the beam. The transmitters have an adjustable power-level. The power-level should be set to the lowest possible that still activates the LED. This will improve the sensors sensitivity.



Cross-Beam Infrared Transmitter/Receiver Specifications				
	Min	Typical	Max	Units
Input Voltage	4.0	4.5	5.0	V
Output Voltage		V _{in}		V
IR Transmitter Current		47		mA
Total Current			100	mA

Cross-Beam Laser Transmitter/Receiver [XBS_L01]



- Two transmitters and two receivers
- 100+ feet (30.5 m) laser range
- Dual-axis triggering
- Conditional triggering (**A** followed by **B**, but within a certain time)
- Optional tripod mount available for sensors
- LED indicator for incident light on receivers
- Two 6 ft 3.5mm and two 6 ft 2.5 mm cables included.

The laser cross-beam sensor provides the same feature set as the IR sensor set above. It has the benefit of additional range when compared to the infrared version. Lasers provide pin-point accuracy for applications that require triggering on small objects. Diffusers are included for the two receivers. The diffusers make aligning the sensors much easier. The lasers have a focusable beam that can be adjusted for the size of the object you are trying to capture.

Cross-Beam Laser Transmitter/Receiver Specifications				
	Min	Typical	Max	Units
Input Voltage	4.0	4.5	4.7	V
Output Voltage		V _{in}		V
Laser Transmitter Current		13		mA
Total Current			30	mA

Beam Receiver [RCVR_02]



Features:

- 6 ft (1.8 m) IR range
- 100+ ft (30.5 m) laser range
- May be used with Laser or IR transmitters
- May be used to measure flash duration
- Includes laser diffuser
- 6 ft 3.5mm cable included
- 4.06" x 2.47" x 1.37" (10.31cm x 6.27cm x 3.73cm)

This sensor is the receiver half of the Beam Sensor. It can be used with an IR or Laser transmitter. Use with LSR_TMTR_01, shown below.

Why would you need a replacement infrared sensor? The most likely answer: Ballistics photography gone wrong. We wouldn't admit to accidentally shooting a sensor either. Your secret is safe with us.

When using the laser transmitter the diffuser will prevent small movements of the receiver or the "speckle" in a laser beam from falsely triggering StopShot. What's "speckle"? It's a phenomenon that occurs in lasers when a correlated light beam experiences interference from waves with different phases. This is often noticed when shining a laser on a surface – It seems to shift and twinkle on its own. Imperfections in the surface can cause the laser light to slightly phase shift resulting in a variance in amplitude. The diffuser also reduces the alignment precision between the transmitter and receiver.



Stand-Alone Beam Receiver and Transmitter Kit [RCVR_03]



Features:

- 6 ft (1.8 m) IR range
- 100+ ft (30.5 m) laser range
- Your choice of either a laser **or** IR transmitter
- Includes laser diffuser if ordered with laser transmitter
- 6 ft 3.5mm and 2.5mm cable included
- 4.06" x 2.47" x 1.37" (10.31cm x 6.27cm x 3.73cm)

This sensor may be used in a stand-alone fashion (i.e., without StopShot). You can select either a laser or IR transmitter to use with it. The included 3.5mm

This sensor is identical to the "Receiver B" of the cross-beam equipment.

Why would you need a replacement infrared sensor? The most likely answer: Ballistics photography gone wrong. We wouldn't admit to accidentally shooting a sensor either. Your secret is safe with us.

When using the laser transmitter the diffuser will prevent small movements of the receiver or the "speckle" in a laser beam from falsely triggering StopShot. What's "speckle"? It's a phenomenon that occurs in lasers when a correlated light beam experiences interference from waves with different phases. This is often noticed when shining a laser on a surface – It seems to shift and twinkle on its own. Imperfections in the surface can cause the laser light to slightly phase shift resulting in a variance in amplitude. The diffuser also reduces the alignment precision between the transmitter and receiver.

Laser Transmitter - [LSR_TMTR_01]



Laser Transmitter Features:

- Long Range (100+ ft)
- 2.5mm Power Jack
- Battery Pack available for Power
- Focusable beam (hand-adjusted)
- 5mW laser Class II Laser Beam
- 650 nm wavelength (red)
- 13mA @ 4.5V
- 6 ft 2.5mm cable included
- 4.06" x 3.40" x 1.37" (10.31cm x 8.64cm x 3.73cm)



⚠ Never look into the laser beam, shine it at someone else, or reflect it off a surface that could bounce back into your (or others) eyes. Laser light damages eyes – which would defeat the purpose of photography.

The laser transmitter is very effective at aiding in the capture of small or very high speed objects. It is also a great way to increase the range between the transmitter and receiver. This makes it very suitable for capturing elusive wildlife such as deer – not that they are small *or* very high speed.

The laser transmitter contains an adjustable lens to focus the beam. When triggering on extremely small objects it is desirable to focus the laser to a narrow beam. Detection of 1 – 2 mm objects is possible.

Laser Transmitter Specifications				
	Min	Typical	Max	Units
Operating Voltage	4.0	4.5	4.7	V
Current Draw		13		mA
Laser Power		5		mW
Beam wavelength		960		nm

Microphone - [MIC01]



The microphone is ideal for impact triggers at close range (a football being kicked or a wine-glass dropping onto a floor). Its trigger sensitivity can be adjusted by the gain control and can detect very faint sounds such as the pop of a soap bubble. This is a condenser microphone and has a 3.5mm mono connector.

Battery Pack for Laser/IR Transmitter - [BAT_PAK_01]



Battery Pack Features:

- Holds 3 AA Batteries (Alkaline recommended)
- On/off switch
- Includes a 3ft cable with a 2.5mm plug (fits Laser and IR transmitters)
- 130+ hour life for laser transmitters
- 50+ hour life Infrared transmitters
- 2.72" x 1.90" x 0.72" (6.90cm x 4.83cm x 1.83cm)
- Short-circuit battery protection

⚠ Make sure this battery pack is switched off when not connected to a laser sensor. If the 2.5mm plug is shorted out excessive heat may be generated and battery life will be greatly diminished.

Battery Pack for StopShot - [BAT_PAK_02]



Battery Pack Features:

- Holds 8 AA Batteries (not included)
- Includes a 16" cable with a 2.1mm plug
- 24+ hour life for StopShot using 2450mAh NiMH batteries
- 2.83" x 2.57" x 1.46" (71.8mm x 65.28mm x 37.08mm)

Hot Shoe Adapter - [HS01]



Features:

- Standard hot shoe with PC connector
- PC connector to RCA adapter included
- ¼" tripod mount on bottom

This adapter lets you connect a flash with a hot shoe to the StopShot module. You will need a RCA to RCA patch cord to complete the connection. The StopShot deluxe kit includes one RCA cable. This hot shoe features a switch to test fire the flash that is connected to it. If everything is connected properly and the button on the hot shoe is pressed, the flash should fire and the corresponding LED on StopShot should be illuminated for the duration of the button press. The hot shoe also has two PC connections on it so additional flashes can be daisy chained.

Water Valve Assembly - [WVA02]



- Fully controllable via StopShot
- 12V DC Power
- 1/4" MPT for mating with siphon
- Mounting screw holes

Great for water drop photos.

This valve assembly can be connected directly to StopShot to create precision controlled drops of water. This valve was used to create many of the "drop crashing into drop" photos in our gallery. It includes a power supply and the cable assembly required to connect it to StopShot.

This valve has a very good response time. When being driven by StopShot this valve is capable of delivering a drop of water with a 30mS pulse. StopShot may be configured to put virtually any delay between drops giving you maximum flexibility when trying to capture water drop photos.

The threads on this valve are 1/4 inch (intended for mating with the Mariotte siphon), and it is powered by 12VDC (supply included). The output nozzle is 1/8 inch.

This valve is also available without the power supply. See the StopShot category on our website for details.

5. Connections & Cables

One of the design goals of StopShot was to make it simple to add cable extensions and do custom wiring. Nothing is more frustrating than buying a product and finding out that it uses over-priced proprietary cables. All StopShot cables are available at your favorite audio/video equipment supply store. We provide the connection diagrams below so that you have the option of making custom cables or sensors. If you have any questions, please contact us at support@cognisys-inc.com.

5.1 Sensor/Mic inputs

The beam sensors and microphone input all use 3.5mm stereo cables. If the supplied cable does not meet your needs you may purchase a 3.5mm stereo “headphone” extension at any audio store.

The microphone input has a 2.2k Ω pull-up to 4.5 volts internally to StopShot to bias the microphone. This connection is on the tip of the 3.5mm microphone plug. The other conductor (the shaft) is ground. See Figure 9 below for a connection diagram.

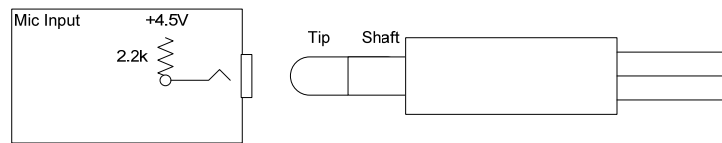

Figure 9 - Microphone Connection

The beam sensor input must also provide power to the sensors. The tip provides 4.5 volts, the center conductor is the signal input, and the remaining conductor is ground. See Figure 10 below for a connection diagram.

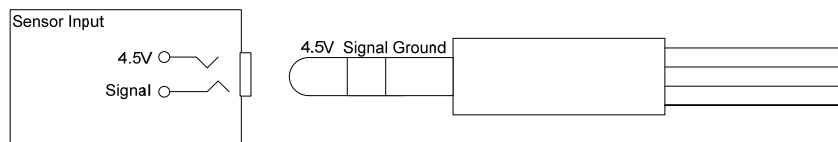

Figure 10 - Sensor Connection

5.2 Trigger Outputs

All the trigger outputs use standard “RCA” jacks. RCA extensions come in all different types, one end as male and the other as female. There are mono (single) extensions which are

typically used for video. Stereo/dual extensions are usually for extending audio connections. There are triple extensions for extending audio and video equipment. You also have the option of buying standard RCA cables and using a coupler adapter to connect two male/male cables together.

As with all RCA jacks the outside connector is ground. StopShot outputs are “Low Side Drivers” (switches in ground). This means that when a trigger output fires, it connects the center conductor of the RCA jack to the outside connector (ground) to draw current through the center conductor.

See Figure 11 below for a wiring diagram for the RCA connectors.

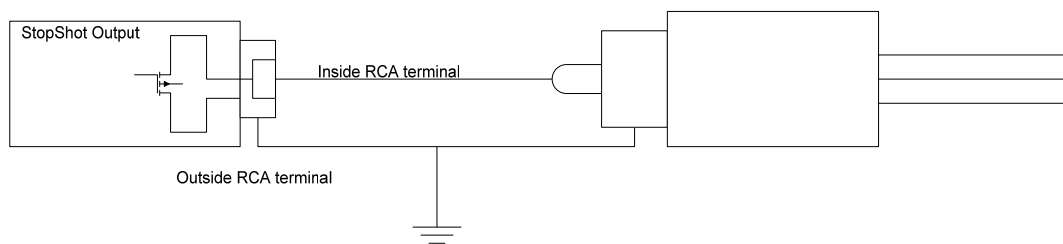

Figure 11 - RCA connector

5.3 Activating Relays

Some applications require activating a relay to enable (or disable) a “load”. Relays allow StopShot to turn on/off a variety of AC and DC devices.

⚠ CAUTION: Care should be taken when wiring up StopShot to control AC or high-voltage DC as a mistake in wiring the relay could cause damage to StopShot and other connected devices.

See Figure 12 below as an example of wiring StopShot to control a 12V DC relay.

Wiring a Relay to StopShot (Low Side Switch)

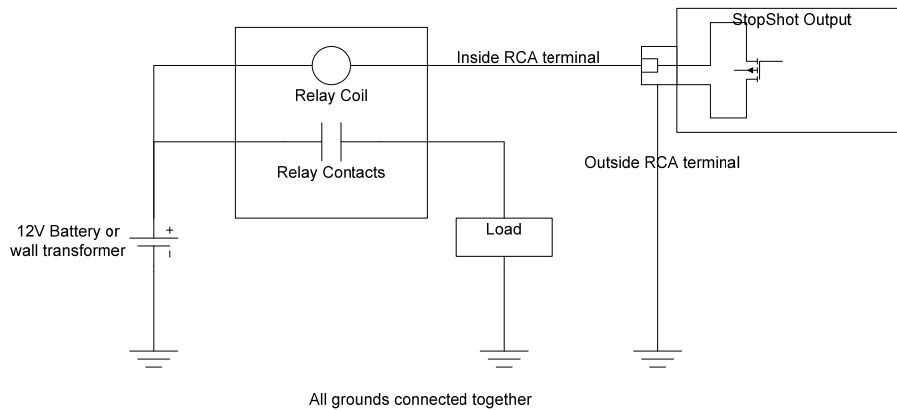

Figure 12 - Wiring an external relay

5.4 Cross-beam Sensor

Both Cross-Beam Receivers are digital sensors. Changing the gain control will not impact the sensitivity of either receiver. The gain should be left in the middle position when using the cross beam sensor set. Receiver A is the sensor with 3 jacks and a LED; it is connected directly to StopShot. Receiver B is the secondary sensor; it has two jacks and is connected to Receiver A. The cross beam sensors are wired as shown below in Figure 13 - Cross-beam connections. Just match the colors. No damage can be done to StopShot or any sensor by connecting them incorrectly. Receiver B can also be connected directly to StopShot if a simple Beam sensor is desired.

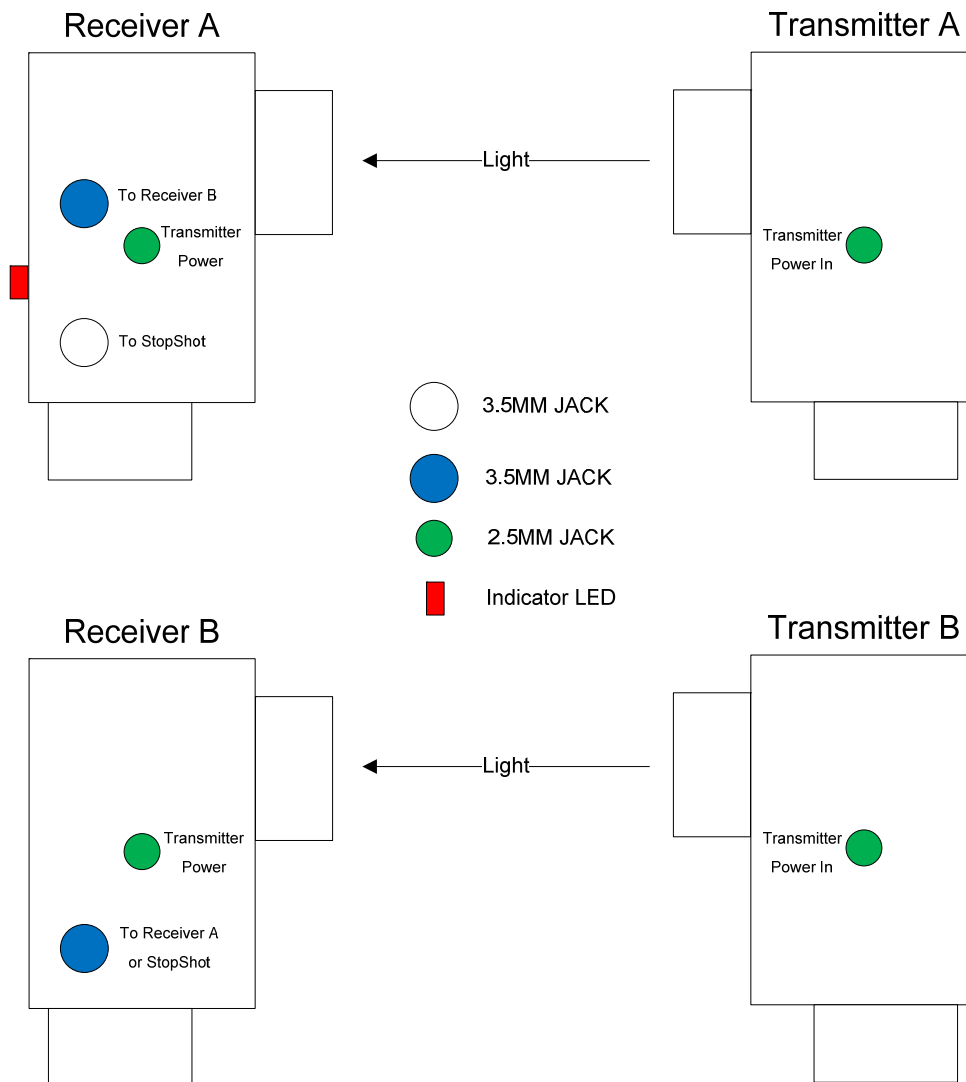

Figure 13 - Cross-beam connections

The cross beam sensor has a tri-colored LED mounted in it to show the status of the sensor. The modes are as follows:

- Red – IR or laser light is incident on sensor A or beam B is broken
- Green – IR or laser light is incident on sensor B or beam A is broken
- Orange – IR or laser light is incident on both sensors

If any of the above lights are on without the corresponding transmitters shining on them there is too much ambient light reaching the sensor. The sensors were designed to be used outdoors but direct sunlight incident on the receiver diodes will cause them to turn on. There is a design tradeoff between good range and ambient light triggering the sensor. To keep response time as fast as possible our sensors do not modulate the infrared transmitters. Modulating a sensor at 20 kHz would add at least 50 microseconds to the response time.

When using lasers as the cross beam transmitters it is best to use the included diffuser (Figure 14) over the both sensors. The diffuser will allow much easier alignment of the laser beams. It will also prevent small movements of either the sensor or the transmitter from causing false triggers. The laser transmitter contains an adjustable lens to focus the beam. When triggering on extremely small objects it is desirable to focus the laser to a narrow beam. Detection of 1 – 2 mm objects is possible.



Figure 14 - Laser Diffuser

Below are some general guidelines for using the sensors:

The sensors work by changes in light produced by objects passing between the transmitter (source) and the sensor (receiver). The object you are trying to capture essentially has to cast a shadow over the small light sensing pin diode internal to the sensor. The diode can be seen inside the sensor (a small black shiny part). If you are trying to capture small objects it is best if the object passes between the receiver and the transmitter as close to the receiver as possible. If you are having trouble triggering on extremely small objects (i.e. 1 -2 mm) it may be necessary to place a small aperture in front of the sensor. Make the aperture as small as possible while maintaining the sensor active light on. The diameter of the aperture will need to be large enough to let enough light reach the photodiode to turn on the photodiode. This diameter will be a function of distance to the transmitter. This technique is more useful for the IR sensor; the laser beam is already very narrow.

If using the laser beams be sure to adjust the beam width for your application using the focusing lens and the end of the transmitters.

When using the infra-red transmitters for cross-beam applications the power-level of the transmitter should be adjusted to the minimum that illuminates the LED indicator for that beam. The power-level is adjusted by turning the knob. Clockwise increases transmitter power while counter-clockwise decreases power. Operating the transmitters with too much power will degrade the sensitivity of the receiver.

6. Trouble Triggering

If there is an idea for a picture that you want to take but can't quite figure out how to make it happen, e-mail us at support@cognisys-inc.com. It doesn't matter how bizarre it is – we might be able to come up with a way to make it happen. If it requires a new feature in StopShot and you are the first one to request it, we'll reprogram your module for free! Just be sure to send us your final picture – we like to see how our product is being used.

7. Setup examples (getting the ultimate shot)

7.1 Water Drops

Water drops are extremely repeatable and fairly easy to set up. The drops can be released by something as simple as an eye-dropper, but for maximum repeatability, we'd recommend using a solenoid-controlled valve. Here is the setup we use:

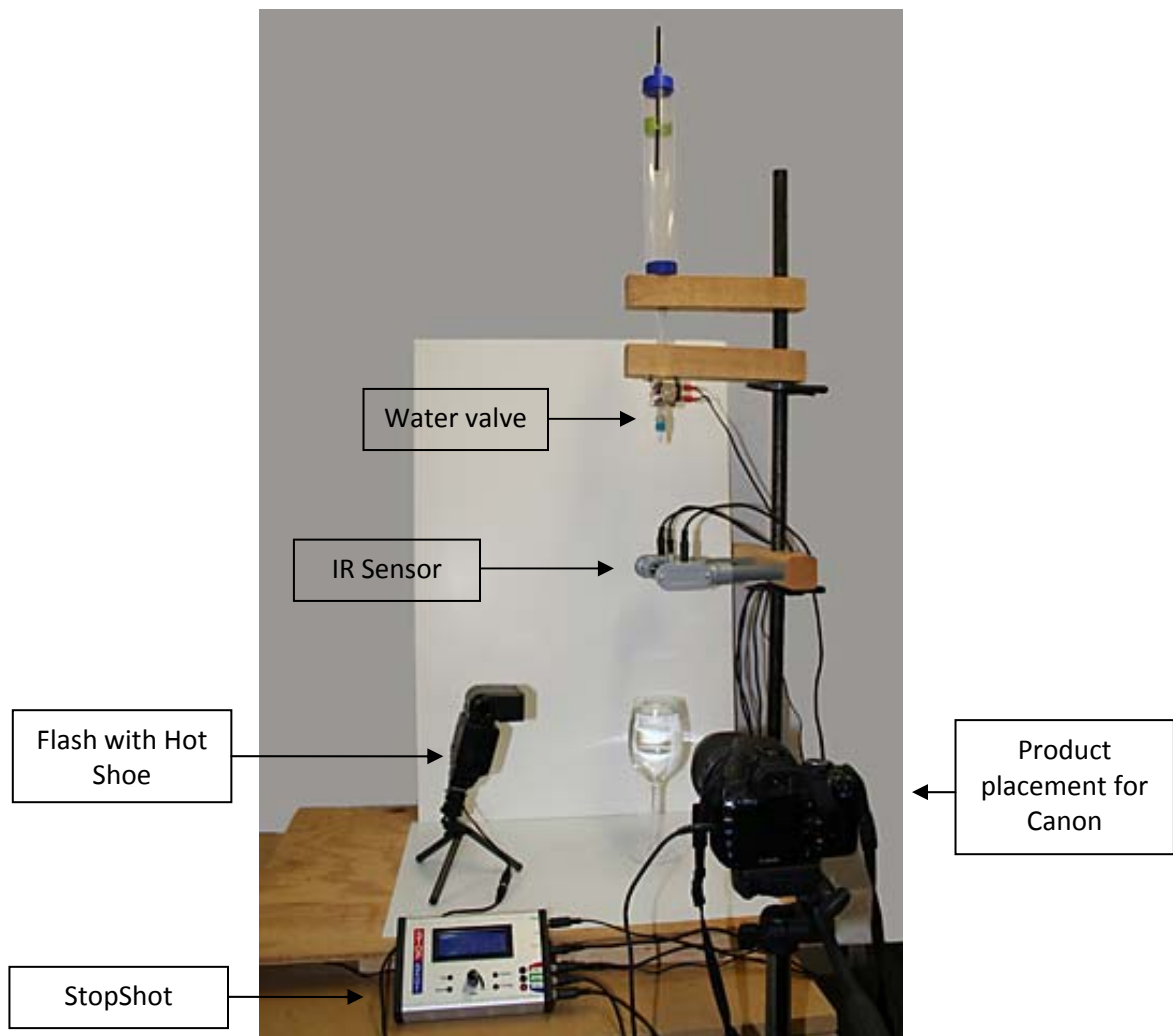

The beam sensor is set up beneath the water drop, and then the delay in StopShot is set appropriately to fire the flash at the desired moment. Because each setup has unique variables, the exact height and settings for the above example aren't given. See section 7.1.1 for details on how to "calibrate" your setup .

You can even let two drops fall, the second colliding with the rebound of the first. The resulting picture:



The water drop falls into a small amount of water inside a glass container. The image beneath the glass is distorted from the waves in the water and also reflected in the drop itself. The depth of the water also affects the rebound and ripple. Try variations – the possible pictures are limitless. Most importantly: Have fun!

With free-falling objects (including water drops), you can use the following formula to estimate the distance travelled, or solving for “t”, the time required from the beam sensor to impact.

$$x = \frac{1}{2} at^2$$

x = the distance traveled

a = acceleration constant of gravity, 32 ft/second² for a result in feet, or 9.8 m/second² for meters.

t = time in seconds

So if the water drop will fall 16 inches to the surface of the water:

$$16 / 12 = 1.33 \text{ feet}$$

$$1.33 = \frac{1}{2} (32) t^2$$

$$t^2 = 0.083125 \quad \text{-- divide 1.33 by } (\frac{1}{2} * 32) \text{ to get } t^2 \text{ by itself}$$

$$t = 0.2883 \quad \text{-- Take the square root of 0.083125}$$

So for a water drop to fall 16 inches, it will take 288.3 milliseconds. The purists out there will note that we're not accounting for air resistance. We'll just call it negligible for this distance.

7.1.1 Water-drop How-to

StopShot has presets saved off as configurations to simplify the water-drop capture process. To take advantage of these settings, refer to section 3.3.2 for loading the desired configuration. These presets make certain assumptions about the physical setup. The sensor bottom must be 19" (48.3 cm) above the surface that the water will fall into. Additionally, the black base of the solenoid valve bottom must be 24" (61 cm) above the surface. Some minor adjustments may be necessary but those presets will save you time in configuring StopShot. If you want to configure StopShot step by step, the instructions follow below.

Step 1: Decent water drops

The first step is getting consistent pictures of single water drops -- we'll get to drop collision pictures in a bit. For best results make sure there is at least 12" of water above the valve. This will give you the water pressure that you'll need for proper operation of the valve. Also be sure to keep the valve, tip, and water container (Mariotte siphon or home-brew container) vertical. The setup: Lights on, no camera, just eyeballs. First we want to start out with StopShot in a known state; Either load one of the presets or this can be accomplished by pressing the **DOWN** button and power up the module. Doing this will restore all of the default settings but it will not delete any setups you have saved. Now that StopShot is in a known state we need to put it into Sequential Mode. To do this press and hold the **CONFIG** button for 2 seconds, press the select button until the cursor is next to "*TMode*". Use the up/down buttons until "*Sequential*" is displayed. Press the **CONFIG** button to exit to the main screen.

Next we need to get the valve set up to trigger on a button press. So with the cursor next to "*Trigger 1*", press and release the config button. This will let you change the settings of just that one output. The display should say "*T1 Mode: Trigger*". Use the up/down buttons until it changes to "*Manual*". Now press the **SELECT** button to move the cursor down to "*Pulse1*". Now use the **DOWN** button to adjust this to the range of 10-20ms. This is the time that the valve will be open to allow water to flow. Adjust "*Toff1*" to 105mS. This is the time between valve openings for multiple drops. For now leave "*# Pulse*" set to "1". "*# Pulse*" defines the number of drops or pulses that will be generated. No drop-on-drop action yet!

Now make sure that the water-valve is plugged into the "*Trigger 1*" output of StopShot and that the valve's AC adapter is plugged into the wall. If the cursor is not next to the "*Manual 1*" line, press the

SELECT button until it is. To activate the manual trigger you need to have the cursor next to the “Manual 1” line. Go ahead and press the **UP** or **DOWN** button and watch the valve. Press it a few times (If there is any air in the line it needs to work out). So take a look for a water drop. Did you get one? If so, do it 20 times in a row. If you get 20 water-drops then Step 1 is complete! If you don’t always get a drop when you press the button then the “Pulse1” time is too short – the valve needs to be open a bit longer. Increase the “Pulse1” time by 1ms and try again (some fine tuning required for a given fluid at a given pressure). After adjusting the “Pulse1” time you need to hit the **CONFIG** button to get you back to the main screen. If on some button presses you get more than one drop (or a stream) then you should bump it down. When the timing is dialed in you should be able to get a single drop every time. This is very important for getting consistent drop collisions later. You need to make sure that for every button press you get exactly one drop, no more, no less. You can adjust the size of the water-drops by slightly increasing or decreasing the “Pulse1” setting – just be sure you don’t adjust it so far that you don’t get one drop consistently.

Step 2: The flash

Press the select button to get the cursor down to “Trigger 2”. In Step 1 we have a water drop falling. Now we need something to set up the timing for the flash. To start you will need to have the flash plugged into the “Trigger 2” output. Now is when you might want to turn out the lights, or at least dim them so you can clearly see the flash illuminate the water drop. (We’re still in eye-ball mode here). So with the cursor on “Trigger 2”, use the **UP/DOWN** buttons to adjust the delay. For the above mentioned distances a good starting point would be 290 – 310 ms. Press the **SELECT** button to get the cursor back up to “Manual 1”, and press the **UP** or **DOWN** button to release the drop of water. At this point you should be able to see the drop of water suspended when the flash fires. If the flash does not fire then something is not right with the setup. Double check the flash and make sure it is turned on, not in sleep mode, and that the wiring is properly connected. If you are not seeing the flash fire, you can verify that StopShot is seeing the drop cross the sensor by looking at the display. If there is a “*” next to “Manual 1” that means that in the sequence that item is complete. For this scenario that is bad because it indicates that “Trigger 2” is still waiting for an input. Check the alignment of the water-drop and the beam sensor. Also check that the transmit power on the IR transmitter is turned down to low (that’s fully counter-clockwise). You do not need the IR lens for water-drop applications. You can double-check the beam sensor is functioning (if there is a “*” next to “Manual 1” indicating it is waiting for the next step which – the beam to be broken) by swinging your finger through the beam. If that completes the sequence and the flash doesn’t fire then something is wrong with the flash setup. If it does fire the flash then there is an alignment issue with the water valve. If the flash fires when dropping the water and you don’t see anything that likely means the delay is not set properly. The flash firing means the water-drop was detected. If you’re not seeing it then it’s probably already hit or is outside the flash range.

At this point you should have it set so every time you press the **UP/DOWN** button that not only a drop of water comes out but the flash fires reliably. Adjusting the delay for “Trigger 2” will change the vertical position of the water drop.

Step 3: Camera Control

Now it is time to get the camera dialed in. You'll need to be in manual focus. You already know the approximate position of the water drop from the previous steps. Use a pencil or something else small at the same position of the water drop to adjust the focus (and set the depth of field as needed).

Set the camera for a bulb mode. In the dark hold the shutter button on the camera and press the **UP** or **DOWN** button to release the water drop, and now you should have a picture of a single water drop. At this point your photos should be very consistent from one picture to the next.

Step 4: Drop-on-drop

Now it is time to get a picture of a drop collision. Multi-drop is really just going back into step 1 and adjusting two parameters. So with the cursor on "*Manual 1*", press the **CONFIG** button and adjust the "*# Pulse*" to "*2*". The trickery comes into play with adjusting "*Toff*". This is the time between releasing the water-drops. Shorter durations means the drops will be closer together, so the rebounding drop will collide with the falling drop very low in the water. Longer durations will have the drop falling into a void created when the first drop is sucked back into the pool from surface tension. Go ahead and leave this the same as you set earlier for now and adjust it as necessary to get the desired effect. Now comes the fine tuning, you will need to adjust the amount of time between the drops and the delay on the main screen to fine tune your setup and get that drop collision photo you are after.

Step 5: Synchronizing the camera

So that wraps up using the long exposure of the camera. The next task: Camera synchronization. At this point you're probably sick of going from StopShot to the camera, back to StopShot, and back to the camera. In a few setting changes everything controlled by one button press (more time spent on the pictures and less time going back and forth).

First, you will need to physically move the connector of the flash from the Trigger 2 output to the Trigger 3 output. Plug the shutter cable into the Trigger 2 output (you did buy a shutter cable, right?). Now it gets kind of tricky. Each camera and model has a shutter lag associated with it. That is the time that it takes from when you tell your camera to take a picture to when it actually does. This lag needs to get subtracted from the delay you had previously used. So if the delay you had entered for "*Trigger 2*" previously was 150ms and your camera's shutter lag is 50ms, then you would want to put in 100ms ($150 - 50 = 100$ ms by using the **UP/DOWN** buttons). If your camera is set to "Bulb" mode, it will leave the shutter open for the duration that StopShot tells it to. Now that the camera is connected to the Trigger 2 output you can press the **CONFIG** button when the cursor is on "*Trigger 2*". The amount of time that StopShot will keep the output active (holding the shutter open) is the "*Pulse1*" setting. In "Bulb" mode, this will control the duration of the exposure. You may also set the exposure time in your camera – provided you know the shutter lag for your camera.

Next we need to configure "*Trigger 3*" for your flash. Press the **SELECT** button so the cursor is on "*Trigger 3*", and then press the **CONFIG** button. Press the **UP** or **DOWN** button to change the "*Mode:*"

to “*Delay*”. Press the **SELECT** button until the cursor is on the “*Sync*” line. Press the **UP** or **DOWN** button to turn this to “*On*”. What this does is tell this output to synchronize with the previous output (“*Trigger 2*”). That means when the previous output first turns on, this output will start. See section 3.6.4 for more details regarding the synchronization feature. Press the **CONFIG** button to get back to the main screen. Almost there! Now the screen should show “*Delay 3:*” Go ahead and adjust this value now. This output will be from when the camera is told to open until the flash fires. So this delay could be very short – but it has to be at least your shutter lag duration. Now when you adjust the delay for “*Trigger 2*” the shutter lag/flash timing will stay the same. You’ll only be adjusting the position of the water-drop. If you don’t see the water drop in the picture then you may not have the proper shutter lag value. Increase it until you reliably see an exposed picture.

There are other settings that would work just as well. StopShot is extremely configurable.

7.2 Water Drop Kit Quick-start

1. Fill siphon so that at least one inch of fluid is above the clear tube that comes down from the top. This will keep the pressure on the valve constant.
2. Make sure the siphon/valve assembly is as vertical as possible.
3. Plug the water valve power into an outlet.
4. Connect the RCA jack from the valve to StopShot "Trigger 1".
5. Connect the infrared sensor to the "Sensor" input on StopShot.
6. From the surface of the water, adjust the valve height (measured from the bottom black body above the nozzle) to 24 inches (61 cm).
7. Adjust the sensor so that the center of the beam is 19 inches (48.25 cm) from the surface of the water.
8. You may either use the pre-stored defaults (global config->load settings) to load the required configuration or enter the following:

Global Config Mode set to Sequential

Trigger 1: Manual

pulses: 1 (or 2 for drop-on-drop). This is the number of pulses that StopShot will give the valve. Each pulse will create one water-drop.

Pulse 1: 15ms – This is the time that the valve will be open.

Toff: 80ms – This is the time between pulses / water drops.

Trigger 2: Trigger 315ms

A triggered input with a main-screen delay of 315ms. Connect the flash to "Trigger 2". The 315ms is the time from when the water-drop crosses the sensor before the flash is fired. For drop-on-drop you may want to adjust this to 290ms depending on the effect you are interested in.

9. Purge any air from the valve by having the cursor next to "Trigger 1: Manual" and press/hold the UP or DOWN button until all air has been removed.



7.3 Ballistics – Tips and Tricks

First we would recommend using the IR light curtain instead of the microphone. There is a surprisingly large amount of variability in timing when using audio (at 1,200 feet per second – a millisecond goes a long ways!). The laser sensors can be complicated to properly align since the beam size is extremely small.

Use or make a large card-board box to contain whatever you plan to shoot. Cut a small hole for your camera, but protect the lens with a piece of Plexiglas. The box serves a couple of purposes, the first is to keep out unwanted light and the second is to contain the mess from whatever you are shooting. The flash should also be protected. Always be aware of your surroundings and who or what is down range. Safety first!

Using a reflective surface on the inside of the box will improve the lighting conditions of the target object. The backdrop for the object will vary depending on what is being shot. If there is a spray of moisture (fruit, vegetables, etc), a black background may be required to see the droplets.

For Ballistics shots like this we built a fixture for the rifle. A fixture makes both hitting the target and triggering StopShot very repeatable. This picture was taken with a Xenon flash (duration = 2uS).



Figure 15 - A Sucker being Shot with a .22 Caliber Rifle

⚠ WARNING: Always use a remote trigger for your camera (wired or wireless) when shooting ballistics photos. Never stand down range from any loaded gun. Seriously. We like repeat customers.

7.4 Wildlife

Capturing wildlife takes on a new dimension with StopShot. There are several sensors available to simply the process of less than cooperative critters.

7.4.1 Lions, Tigers, and Bear

The “Passive IR sensor” is a single-sided sensor (no reflector or other part required) with a range of about 16 feet (5m). A simple setting example is shown below:

```
== StopShot ==  
> Trigger 1: 100.0 ms  
   Trigger 2: Off  
   Trigger 3: Off
```

With these settings, “Trigger 1” output would fire 100ms after the sensor detects movement in its beam. Unfortunately the sensor may continue to fire if the creature pauses, moves slowly, or decides it is time to graze. To prevent the sensor from re-triggering StopShot you may want to adjust the “blinking time” so that StopShot ignores the sensor for a period of time. “Blinking time” is discussed in more detail in section 3.5.3.

This sensor uses passively radiated heat from objects to detect movement. It’s ideally suited for capturing larger animals. Small fast-moving critters may not be detected – but don’t worry. We have them covered as well with other sensors.

“Laser transmitters” allow a much further distance between the receiver and transmitter than it’s infrared (IR) counter-part. This beam, tested at 60 feet (18.3m) before we ran out of room, gives maximum range for the less-scripted wildlife. If you know an area that they may be traveling in but can’t pin down exactly where the laser transmitter would be a perfect weapon in your sensor arsenal. These settings would be the same as those above. The transmitter can be powered by the 2.5mm cable from the receiver but for long distances it would be wise to consider using a laser transmitter battery pack.

7.4.2 Of Mice and Men

If you’re down-scaling from deer to mice, you might consider the “Vibration sensor”. If StopShot’s gain is set to maximum this sensor may detect the gaze of a mouse (okay, that’s not entirely true, but you get the idea). This sensor could be hidden beneath leaves or in the grass and will trigger

with the slightest of movement. Don't just rule this out for ground-traveling wildlife though. It could also be placed in a bird's nest or branch to detect a landing. The settings for this are the same as that above.

7.4.3 The Catch-All

Cross-beam sensors. It's for the birds. No Really. And bats. Snakes. Bees. Wasps. Deer. Antelope. Cantaloupe. Anything that moves. The cross-beam sensor isn't simply for triggering in a pin-point spot in space (which it excels at!). It allows you to also stage the two beams so that it will only trigger if the subject of interest is moving at a specific speed.

Section 3.5.4 of this manual describes many of the operating modes of the cross-beam sensors. Now let's discuss a couple of real-world scenarios.

Birds:

Guardians of the sky, envy of the Wright brothers, and buggers to capture with a camera.

The Deer:

The upper-peninsula of Michigan has more deer than humans. Clearly they are a threat to our very existence and their nefarious activities must be documented with photos and film. In this example we want to capture a deer running at full speed. Grazing deer aren't much of a concern – it's the running ones that are up to no good. For this situation, the cross-beams will be staggered. After thorough research on the internet (which never lies), the maximum speed of a White Tail Deer is 30 mph (48 kph). We'll configure StopShot to trigger on a deer running at 15 mph or faster.

Here is the physical setup:

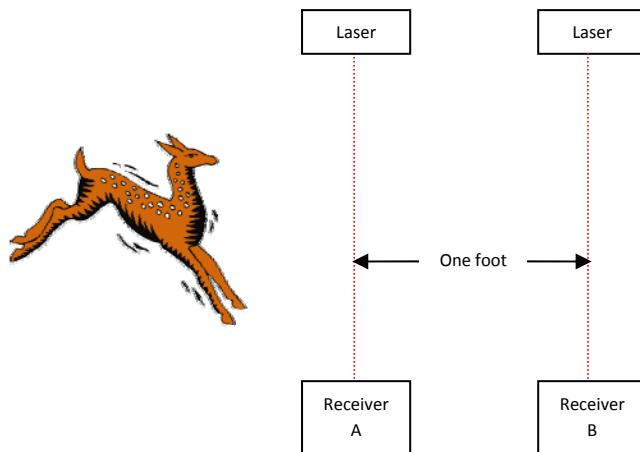

So let the StopShot configuration begin.

We'll be using independent mode for this capture. By holding down the **CONFIG** button, make sure that the global configuration mode for StopShot is set to *"Independent"*.

```
== Global Config ==
> TMode: Independent
Load/Save Config
Load Defaults: ->
```

Press the **CONFIG** button again to get back to the main screen:

```
== StopShot ==
> Trigger 1: Off
Trigger 2: Off
Trigger 3: Off
```

Now we want to change the “Trigger 1” output to the cross-beam sensor. In this case we want the sensor to trigger when the deer runs across sensor A to sensor B, so we’ll choose the “X-Beam a->b” mode. Since the cursor is already on “Trigger 1”, press the **CONFIG** button quickly to bring up the configuration for that output:

```
> T1 Mode: Trigger
# Pulse: 1
TPulse1: 500.0 ms
Toff1: 100.0 ms ->
```

Using the **UP** or **DOWN** buttons, change the “T1 Mode” until it says “X-Beam a->b”:

```
> T1 Mode: X-Beam a->b
# Pulse: 1
Pulse1: 500.0 ms
Toff1: 100.0 ms ->
```

We’re not quite done yet though. Now we need to adjust the timeout for this trigger. To simplify the math, let’s say the two sensor beams are one foot away. 15 mph is $(15 * 5280) = 79,200$ feet per hour. The sensor’s timeout is in seconds, so one more calculation: $79,200 \text{ feet per hour} / 60 / 60 = 22$ feet per second. That’s pretty fast. If my sensors were spaced 22 feet apart, I would set the timeout to one second. But they aren’t – they are one foot apart. So if the deer goes 22 feet in one second, it would take them $(\text{one second} / 22 \text{ feet})$ to go one foot, or 45ms. Now we have a magical number to feed StopShot. Press the **SELECT** button until the “Timeout” field shows:

```
> Timeout: 250.0 ms
Blank: Off ->
```

Use the **DOWN** button to adjust the “timeout” to “45.0 ms”. The **CONFIG** button will take you back to the main menu.

There we go! We now have a cross-beam configured to capture a deer running at 15 mph. One problem. We don’t know which direction the deer is going to come from (they’re pesky that way),

and this channel is only configured for “X-Beam a->b”. If the deer comes from the other direction, the sensor won’t fire (by design). That’s one of many reasons that StopShot has multiple outputs. All you have to do is configure “Trigger 2” for “X-Beam b->a” with the same settings. This will require an external RCA “Y” cable to tie the two StopShot outputs together, and then run it to your camera via a shutter cable.

So now on the main-screen you should see:

```
== StopShot ==  
> XBS a->b: Off  
  XBS b->a: Off  
  Trigger 3: Off
```

Use the **UP** button to change the “Off” for both outputs to something reasonable, like 1.0 ms. This will be the delay from when the sensor has detected something to when the output is activated. Why 1.0ms instead of 50us? We need to give a little time for the sensors to turn off.

One last improvement is to get rid of the laser beam from the pictures. To accomplish this we’ll use the “Power Off” feature in StopShot (see section 3.3.5 for more details). After holding down the **CONFIG** button to get to the global configuration, press the select button until the “Pwr Off” field is shown:

```
== Global Config ==  
  LCD Backlight: 10  
> Pwr Off: None  
  Pwr Toff: 250.0 ms ->
```

Use the **UP** or **DOWN** buttons until “All” is displayed. 250ms will be reasonable enough for the camera to take a picture with the laser light off.

So there we have it. A bi-directional speed-sensitive setup to capture deer traveling at least 15 mph.

8. Animated Time-Lapse movies

By using the “Time Lapse” global configuration you can generate a sequence of pictures. There are some freely available programs that can convert a series of JPEG pictures into an MPEG or AVI movie. For information on these programs and the latest links to the software, please visit our website at: <http://www.cognisys-inc.com>.

When taking a series of time-lapse pictures, you may or may not want to disable the auto-exposure feature of your camera. If capturing a sunset, you may want the light to progressively dwindle into nothing, instead of the camera increasing the exposure time to compensate for the low-light. Some experimentation may be required.

9. Troubleshooting

Problem	Cause	Solution
Display is not lit.	Power cord is not inserted properly into the power jack.	Insert the power cord properly into the power jack. It needs to be fully seated in the connector.
	Power cord is not plugged into the wall.	Plug power adapter into the wall.
	Wrong AC/DC adapter used.	Be sure to use the AC/DC adapter that was included with your StopShot module.
	Backlighting is turned down too low.	If the backlighting was turned down to use in the dark, you may not be able to see it in bright light. In a room with less light, adjust the backlighting per the manual.
Trigger LED's are constantly on or flashing.	The wrong timer mode is selected.	Please verify that the timers are being used correctly. If you need to reset the settings to the factory default, see the section "Global Reset".
	The gain is set too high.	If the timer is using the input trigger, turn the gain towards the MIN indicator (CCW).
	The trigger output has a short circuit.	Disconnect the load (flash, accessory, etc) from StopShot and see if the light goes out. If it does, something is wrong with the load.
	Your load (flash, accessory, etc) is not powered up.	The load may have a slightly resistive path to ground. Power up the load.
Camera or flash does not trigger	Equipment in sleep mode.	Ensure equipment is in ready mode.

If you cannot resolve a problem with the StopShot module, please contact us at support@cognisys-inc.com. We want to make sure that you are completely satisfied with our product.

10. Specifications

Specifications are intended for reference only. The design may be modified to improve features or functionality without notice.

- Fully programmable 3 channel intervalometer.
- 4x20 LCD Display with adjustable blue backlighting.
- Powered by a high-speed Freescale Digital Signal Processor
- All outputs are open drain (Can be used for Flash Trigger or Shutter Trigger).
- Microphone Input for standard electret microphone.
- Input sensor jack with external power for IR LED's, Lasers or other 5Vdc loads.
- Outputs have enough current capability to energize relays or electronic valves (Outputs are protected from inductive loads).
- All outputs short circuit protected.
- Accepts DC Input 2.1mm power jack.
- Simple 4 button interface.
- Adjustable gain for microphone and sensor inputs.
- Standard 3.5mm microphone jack.
- RCA output cables (easy and affordable to extend).
- Durable extruded aluminum housing.

Specifications	MIN	NOM	MAX	UNITS
Input Voltage	6	7.5	14	Vdc
Input Current - No Sensors Connected (9Vdc in)	-	75	100	mAdc
Output Current Sink	-	-	1	Adc
Sensor Supply Output Voltage	4.0	4.5	5.0	Vdc
Sensor Supply Output Current	-	-	100	mAdc
Max Voltage on Trigger Out Port (Steady State)	-	-	60	Vdc
Timer Tolerance @ 25C (standard module)		1		%
Timer Tolerance @ 25C (Precision Timing Opt)		50		Ppm
Operating Temperature	-20	25	50	C

11. Warranty

Limited Warranty

All products are warranted to be free from defects in materials or workmanship for one (1) year from the date of purchase. Within this period, Cognisys Inc. will, at its sole option, repair or replace any components which fail in normal use. Such repairs or replacement will be made at no charge to the customer for parts or labor, provided that the customer shall be responsible for any transportation cost. This warranty does not cover failures due to abuse, misuse, accident or unauthorized alterations or repairs.

THE WARRANTIES AND REMEDIES CONTAINED HEREIN ARE EXCLUSIVE AND IN LIEU OF ALL OTHER WARRANTIES, WHETHER EXPRESS, IMPLIED OR STATUTORY, INCLUDING ANY LIABILITY ARISING UNDER ANY WARRANTY OF MERCHANTABILITY OR FITNESS FOR A PARTICULAR PURPOSE, STATUTORY OR OTHERWISE. THIS WARRANTY GIVES YOU SPECIFIC LEGAL RIGHTS, WHICH MAY VARY FROM STATE TO STATE.

IN NO EVENT SHALL COGNISYS BE LIABLE FOR ANY INCIDENTAL, SPECIAL, INDIRECT OR CONSEQUENTIAL DAMAGES, WHETHER RESULTING FROM THE USE, MISUSE OR INABILITY TO USE THE PRODUCT OR FROM DEFECTS IN THE PRODUCT. SOME STATES DO NOT ALLOW THE EXCLUSION OF INCIDENTAL OR CONSEQUENTIAL DAMAGES, SO THE ABOVE LIMITATIONS MAY NOT APPLY TO YOU.

Cognisys retains the exclusive right to repair or replace the product or offer a full refund of the purchase price at its sole discretion. SUCH REMEDY SHALL BE YOUR SOLE AND EXCLUSIVE REMEDY FOR ANY BREACH OF WARRANTY.

12. Glossary

Term	Description
# Pulse	Number of output pulses that a trigger output will generate.
Ballist	Ballistics mode. This will measure the time it takes to cross two sensors and fire the output a configurable distance multiplier (“Dist Mult”) from the last sensor.
Blank	The blanking time is the duration where StopShot will ignore the input. This may be useful to ignore second drops, transients, or flashes.
Dist Mult	For ballistics mode, this is the distance multiplier used for when it should fire the trigger output. If the sensors are six inches apart and “Dist Mult” is set to four, the output would fire when the object is 24 inches from the last sensor.
F Duration	Flash Duration. A global triggering mode. This will measure the duration of a flash provided it is less than 3 ms.
Gain	Amount of amplification applied.
Incrn	Abbreviation for increment. The increment value will be added to the delay setting every time there is an input event.
Independent	A global triggering mode where all the triggers operate independent from each other.
Latched	When an output stays in a given state (on or off).
LCD Backlight	The backlighting for the LCD allows the text to be visible. It is adjustable so that for low-light conditions it won’t ruin long exposures.
Load Defaults	Load the factory defaults for all the settings.
ms	Abbreviation for milliseconds. A thousandth of a second (1/1000 seconds).
Pwr Off	Power-Off. This lets you choose which trigger output will disable the sensor power. The moment an event is detected the power will be turned off. This is useful for eliminating red laser light from being in pictures. You can choose from no outputs, all of them, or each individual output to cause the disabling of the power.
Pwr Toff	Power Time Off. This is the duration that the sensor power will be disabled.
SEQ	The global configuration is set to “Sequential Mode”. This means that the trigger configurations will follow in sequence. The opposite is independent mode where they all function at the same time.
Sequential	A global triggering mode where the triggers operate sequentially. That means that the following trigger won’t start until the current one completes.
Short Circuit (short)	To connect two wires together. Provide a path for current to flow with low resistance.
Shutter lag	This is the delay from when a camera is told to take a picture and when it actually takes it. The camera performs several functions prior to taking the picture (focusing, metering, etc) which can all add a delay. To make matters worse it may even be a variable delay.
Sync	Synchronization mode. This is only available for the “delay” setting in sequential mode. When this is set to “Yes”, the delay will start when the output of the previous trigger goes high. StopShot typically starts the next trigger when the output goes low (Sync mode set to “no”).
Timeout	The time an input mode will wait for a specific event.
TLapse	Time-lapse. A method of taking pictures at a given interval.

TMode	Trigger Mode. This is a global configuration that lets you choose the behavior of StopShot. Examples are: Independent, Sequential, Time Lapse, Flash measurement, etc...
Toff	The time off between output pulses.
Trigger	When one of the three channels is configured as "Trigger", it will fire the output after a configurable delay after seeing an input.
Trigger Output	One of the three outputs of StopShot. The Red LED's correspond to the three outputs.
us	Abbreviation for microseconds. A millionth of a second.
Waiting	Displayed when an output is configured for "Manual" mode. Pressing the UP or DOWN buttons will start the manual output, changing the displayed text to "Active".
X-Beam	Short for "cross-beam". Two beams are set in an X formation that allows for pin-point detection. StopShot's cross-beams may also be used in a staggered method so that beams have to be crossed in a specific direction.
XBS A	Cross-beam sensor A. StopShot will fire when only the "A" sensor is crossed.
XBS A&B	Cross-beam sensors A and B. StopShot will fire only when both sensors are crossed simultaneously.
XBS A B	Cross-beam sensors A or B. StopShot will fire when either A or B are crossed.
XBS A->B	Cross-beam sensor A followed by B. StopShot will only fire when A is triggered followed by B. A timeout is selectable to reset this mode should B not happen within a reasonable amount of time.
XBS B	Cross-beam sensor B. StopShot will fire when only the "B" sensor is crossed.
XBS B->A	Cross-beam sensor B followed by A. StopShot will only fire when B is triggered followed by A. A timeout is selectable to reset this mode should A not happen within a reasonable amount of time.

13. Revision History

Revision	Date	Change
1.0	06/02/08	Initial Release
1.1	11/21/08	Updated product portfolio and additional sensor modes.
1.2	12/19/08	Added X-beam A/B mode, sequential mode timeout, and StopShot battery pack. TX power switch added to IR beam sensor.
1.3	02/17/09	StopShot 1.0.06 SW features: Ballistics mode Sensor Power Disable Adjustable infrared transmitter power for single and x-beam.
1.4	03/09/09	StopShot 1.0.07 SW features: User settings may be stored into 10 locations. Output pulse setting may be “latched on” in sequential mode StopShot 1.1.00 SW features: Delay allowed as first trigger mode in sequential operation
1.5	03/20/09	Multiple pulses added to all timer modes.
1.6	05/29/09	Water-drop “How-To” added.
1.7	11/12/09	StopShot 1.1.04 – 1.1.06 features: Valve priming simplifies water-drop set-up Shutter-lag measurement Tpulse2+ added as a new configurable Presets loaded for out-of-the-box water drop photography
1.8	08/05/10	StopShot 1.1.07 features: Added Tpulse3, Toff3. All trigger modes communized for configuration (3+ pulses for all) Manual mode now available for all triggers in sequential mode
1.9	12/1/10	Added Water-valve quick-start section